



SCIENCE REPORT
2017

PREFACE

Dear Friends and Partners of Fraunhofer FHR,
Dear Reader,

2017 was an eventful year with many activities and a number of highlights. Fraunhofer FHR reached some important milestones, particularly in the business unit Space. At the beginning of 2017 and within the framework of the new project WRIS (Space Identification Sensor), Fraunhofer FHR carried out its first observation and analysis assignments with the space observation radar TIRA. Our partner in this project is the German Space Situational Awareness Center (Deutsches Weltraumlagezentrum), which is operated by the German Air Force and the German Aerospace Center (DLR) in Kalkar on the Lower Rhine. Work on GESTRA (German Experimental Space Surveillance and Tracking Radar) is also forging ahead. The system, which was commissioned by the aerospace management of the German Aerospace Center, is currently in the integration phase. Once it has been completed and handed over to the German Space Situational Awareness Center, it will be a further cornerstone for seamless, radar-supported space surveillance. Hence, the space observation radars of Fraunhofer FHR play an important role in the protection of space-based infrastructure.

Fraunhofer FHR also incorporates its special abilities and know-how into the Research Factory for Microelectronics Germany (Forschungsfabrik Mikroelektronik Deutschland (FMD)). Within the framework of FMD, the Federal Ministry of Research and Education provides funding for 13 non-university research institutions in the amount of approx. 350 million euro. Fraunhofer FHR will invest a considerable share of the 9.3 million euro it receives from the investment program in the construction of state-of-the-art on-wafer and antenna measurement techniques as well as on the development of a 3D production system for rapid prototyping. The institute is also creating two modern IEEE-compatible measurement chambers for the measurement and qualification of completed systems and antennas. The chambers will cover the frequency range from 100 MHz to 1.1 THz. In June, the Parliamentary State Secretary Thomas Rachel MdB gave the official go-ahead for FMD in Wachtberg.

Further important developments also took place in the personnel area: with effect from 1st September 2017, the Institute Director Dr. Peter Knott was appointed professor at the RWTH Aachen University where he lectures on »Radar System Technology« at the Institute for High Frequency Technology (IHF) in the faculty of Electrical Engineering and Information Technology. This further strengthens the cooperation with RWTH. On commencement of his professorial duties, he was presented with the Certificate of Appointment by Rector Prof. Dr. Ernst Schmachtenberg. Dr. Frank Weinmann took over from Prof. Dr. Knott as Head of the AEM Department with effect from 1st March 2017. Fraunhofer FHR also has two new departments: the MHS Department was split



up into the departments ISS and HRA. These are headed by Dirk Nüßler (ISS) and Dr. Stephan Stanko (HRA). Heiner Kuschel, Head of the PSR Department, went into well-deserved retirement at the end of 2017 and handed over the leadership of his department to Prof. Dr. Daniel O' Hagan. Prof. Dr. Jens Bongartz took over as head of the thematically enlarged business unit »Human and Environment«. The newly created area »Human« explores possibilities for the utilization of high frequency electromagnetic radiation in a medical and personal environment. Non-contact measurement and the ability to penetrate materials open up many possibilities in the areas of medicine and ambient assisted living: the precise (Doppler) measurement of the smallest movement allows, for example, the contact-free recording of vital parameters. The ability to locate people paves the way for the discreet monitoring of older or disadvantaged persons so that assistance can be rendered quickly in the event of an emergency.

In addition to the popular in-house exhibition »Wachtberg Forum« which is held annually, we also organized an Open Day event this year as part of the institute's 60th anniversary celebrations. The level of interest shown by the local residents was enormous! On 28th June, approximately 2,500 visitors came to Wachtberg to gain an insight into our research in the areas of defense, space, traffic, environment, security and production. The chance to have a look inside the radome was a highlight for many, but the exhibition and lectures were also very well frequented. The employees answered many questions relating to their exhibits. These were posed by young and older visitors alike. We would like to thank all involved for their tremendous commitment in the preparation and realization of this day!

We would also like to take this opportunity to thank all of the cooperation partners of Fraunhofer FHR for the trust and confidence they placed in us – above all, those institutes that supported our research activities and our partners from business and industry.

Dear Reader, we are pleased to provide you with an overview of our wide-ranging activities. Our scientists have worked on numerous projects and themes. A selection of these are presented in our Annual Report 2017. We wish you stimulating reading!



Executive Director:
Prof. Dr.-Ing. Peter Knott
Phone +49 228 9435-227
peter.knott@
fhr.fraunhofer.de



Director:
Prof. Dr.-Ing. Dirk Heberling
Phone +49 228 9435-176
dirk.heberling@
fhr.fraunhofer.de

Peter Knott, March 2018

Dirk Heberling, March 2018

TABLE OF CONTENT

- 2 Preface
- 4 Table of content

6 FROM THE INSTITUTE

- 6 Special events 2017
- 10 Official go-ahead for the Research Factory for Microelectronics Germany (FMD) at Fraunhofer FHR
- 12 Wachtberg-Forum and open day
- 14 EDA-Workshop »Radar Signatures & EM Benchmarks«

16 OVERVIEW

- 16 Fraunhofer FHR in Profil
- 20 Organization Chart of Fraunhofer FHR
- 22 Advisory Board
- 24 From theory to practice: Research groups at univeritys
- 26 Interview Dr. Udo Uschkerat:
»Serving the Fraunhofer Idea«
- 28 Business Units

30 RESEARCH REPORTS

- 30 Airborne multifunction radar of the next generation
- 32 SAR imaging from interrupted measurements
- 34 German-Swiss cooperation between Fraunhofer FHR and armasuisse S&T
- 36 Active protection system with millimeter wave radar
- 38 Defense against hypersonic missiles
- 40 DVB-S2-based passive radar imaging
- 42 Cryogenic phased array radars for space surveillance
- 44 Characterization of the small-size space debris population with TIRA

- 46 Surveillance of near-earth space with a radar network
- 48 Demonstration of a solid-state radar for maritime navigation
- 50 Antenna development for an innovative sea rescue system
- 52 UWB Radar for the detection of fungal infestation in vines
- 54 COLORS: another step towards bird protection in wind farms
- 56 RAWIS protects rescuers during emergencies
- 58 Drone detection with micro-doppler analysis
- 60 Width determination of steel strips in the rolling process – radar systems for industrial applications
- 62 3D radar images for transmissive inspection of objects with transmitted light
- 64 Identification with millimeter wave tags
- 66 Reliable qualification of automotive radars with ATRIUM
- 68 Characterization and design of SIW components and antennas

70 Annex

- 70 Publications
- 72 Education and training
- 78 Committee Work
- 82 Awards
- 83 Events
- 84 Press Reviews
- 86 Locations

88 IMPRINT

FROM THE INSTITUTE



SPECIAL EVENTS 2017

Wachtberg, 1.1.2017

New departments ISS and HRA

Due to strong growth and the strategic orientation of both sections, the former MHS Department was split up into two departments: the new department »Integrated Circuits and Sensor Systems« (ISS) is now headed by Dirk Nüßler and the second new department »High Frequency Radar and Applications« (HRA) is under the leadership of Dr. Stephan Stanko.

Wachtberg / Uedem, 7.3.2017

Fraunhofer FHR and the German Space Situational Awareness Center (Deutsches Weltraumlagezentrum) expand cooperation

Within the framework of the new project WRIS (Space Identification Sensor), Fraunhofer FHR carried out its first observation and analysis assignment with the space observation radar TIRA. The German Space Situational Awareness Center is a partner in this project.

Wachtberg, 14.03.2017

Workshop: Radar technology for UAV detection

In a fully-booked workshop, researchers and industrial partners presented their solutions in the area of UAV detection. The highlight was the live presentation of the detection systems from Fraunhofer FHR. Around 100 participants discussed application scenarios and the possibilities of radar for UAV detection.

Wachtberg, 22.03.2017

Award: Bastian Rahlf is the best precision mechanics apprentice in the region

Bastian Rahlf completed his precision mechanics studies as Student of the Year at the trade guild Bonn-Rhine-Sieg. He was subsequently invited to the annual awards ceremony for the best trainees at the Fraunhofer-Gesellschaft.

Prof. Dr. Ernst Schmachtenberg (Rector of the RWTH Aachen University) presented Prof. Dr. Peter Knott with the Certificate of Appointment.

Wachtberg, 1.4.2017

Dr. Udo Uschkerat is appointed full-time spokesperson for the business unit Defense

The experienced scientist Dr. Udo Uschkerat represents the interests of the institute at corresponding committee meetings and events, advises the directors of the institute with regard to the development of the business unit Defense and promotes cooperation between the active employees in the business unit.

Darmstadt, 18-21.4.2017

7th European Conference on Space Debris

Fraunhofer FHR was well represented at the most important conference on space debris which attracted around 350 international participants. The institute presented both of its systems, TIRA and GESTRA. Moreover, specialist presentations were given by Dr. Delphine Cerutti-Maori, Svenja Sommer and Helmut Wilden. Dr. Ludger Leushacke chaired the session »Radar, Optical, and in-situ Measurements – ground based«. GESTRA attracted a great deal of attention in the course of the conference. The German Minister for Economic Affairs Brigitte Zypries acknowledged the system in the closing press conference.

Wachtberg, 27.4.2017

Girls' Day

For the 17th time, girls of various ages visited Fraunhofer FHR. They built radios or electronic modules in different workshops, had a look around an electronic laboratory, programmed Lego robots or learned about the responsibilities of a precision mechanic.

Stuttgart, 09-12.5.2017

Control Exhibition

Fraunhofer FHR presented the new generation of high frequency sensors at a stand shared with the Fraunhofer-Gesellschaft. These allow the non-contact, non-destructive testing of a wide variety of goods.



Wachtberg, 23-24.5.2017

6th PCL Focus Days

Around 80 international passive radar experts met for the sixth time in Wachtberg at the PCL Focus Days to exchange information on the latest research results in this area.

Wachtberg, 6.6.2017

Official go-ahead for the Research Factory for Microelectronics Germany at Fraunhofer FHR

(see detailed article on page 10)

Wachtberg, 22.6 & 25.6.2017

Wachtberg Forum & Open Day

(see detailed article on page 12)

Berlin, 5.7.2017

RAWIS project presented to the Federal Minister for Education and Research Wanka and the Federal Minister of the Interior de Maizière in Berlin

At a joint press conference of the BMBF and the BMI on the research framework »Civil Security«, the project Radar Warning and Information System for Use for Applications in Disaster Control (RAWIS) was presented to the Federal Ministers Johanna Wanka and Thomas de Maizière.

Remagen, 14-21.7.2017

9th International Summer School on Radar/SAR

45 participants from all over the world attended the 9th International Summer School on Radar/SAR. Fraunhofer FHR holds this event on an annual basis. In addition to the intensive workshops on radar and, in particular, SAR, a corresponding accompanying program is provided for the participants.

Aachen, 1.9.2017

Institute Director Dr. Peter Knott is appointed professor at the RWTH Aachen University

Prof. Dr. Peter Knott lectures on »Radar System Technology« at the Institute for High Frequency Technology (IHF) in the faculty of Electrical Engineering and Information Technology at RWTH Aachen University.

Bonn, 12.9.2017

Award: AFCEA Student Award for Olaf Lambert

Olaf Lambert was awarded second place for his thesis at the AFCEA Bonn e.V. Student Awards 2017. The master thesis is titled »Adaptation and Implementation of System-Inherent HF Characterization Methods for a Receive Module based on the SDR Principle for a Phased Array Radar«.

Bonn, 14.9.2017

Company Run Bonn

Fraunhofer FHR and FKIE once again started as a joint team at the company race in Bonn. The number of participants tripled compared to the previous year: 72 employees took to the start despite the rainy conditions.

Frankfurt / Oder, 6.9.2017

Award: International IHP »Wolfgang Mehr« Fellowship Award 2017 for Prof. Dr. Nils Pohl

Prof. Dr. Nils Pohl received the international IHP »Wolfgang Mehr« Fellowship Award 2017. He was honored for his research in the area of high frequency electronics on a silicon-germanium (SiGe) basis.

Nuremberg, 8-13.10.2017

European Microwave Week

The cooperation with TNO was continued. Fraunhofer FHR, Fraunhofer IAF and TNO jointly exhibited their new technologies from the millimeter wave and terahertz systems area.



Bremen, 24-26.10.2017

Space Tech Expo Europe

Fraunhofer FHR presented its GESTRA project at a stand shared with Fraunhofer-Allianz Space.

Wachtberg, 1.11.2017

New business unit »Human and Environment«

Medical technology – this is the new focal point of the cooperation between Fraunhofer FHR and the University of Coblenz, RheinAhrCampus Remagen. Prof. Dr. Jens Bongartz is appointed spokesperson of the business unit »Human and Environment« with effect from 1st November 2017.

Brussels, 7.11.2017

EDA workshop »Radar Signatures & EM Benchmarks«

(see detailed article on page 14)

Munich, 14-17.11.2017

Productronica Exhibition

Within the framework of FMD, Fraunhofer FHR was represented at the joint stand of the Fraunhofer-Gesellschaft. The compact and versatile SiGe radars were presented along with the latest developments in the area of special antennas on conform surfaces.

Jakarta, Indonesia, 21-23.11.2017

Award: Best Paper Award for Thomas Vaupel

Thomas Vaupel received the Best Paper Award at the International Conference on Broadband Communication, Wireless Sensors and Powering (BCWSP 2017) at the University of Mercu Buana in Jakarta. He won the prize for his collaboration with Prof. Dr. Volkert Hansen from the Bergische University of Wuppertal on the paper »Application of a TSMFM Planar-3D Fast Integral Equation Solver for Surface Wave Characterization of Antenna Arrays«.

1 Dr. Jens Klare discussed the RAWIS project and the MIMO radar with the Federal Minister for Education and Research Johanna Wanka and the Federal Minister of the Interior Thomas de Maizière.

2 Prof. Dr. Dietmar Kissing, Prof. Dr. Nils Pohl and Prof. Dr. Rolf Kraemer (l-r.) at the presentation of the International IHP »Wolfgang Mehr« Fellowship Award.

3 Dr. Thomas Vaupel received the Best Paper Award at the International Conference on Broadband Communication, Wireless Sensors and Powering.



Head of
Internal and external Communication:
Dipl.-Volksw. JENS FIEGE
Phone +49 151 613 653 67
jens.fiege@fhr.fraunhofer.de

FROM THE INSTITUTE

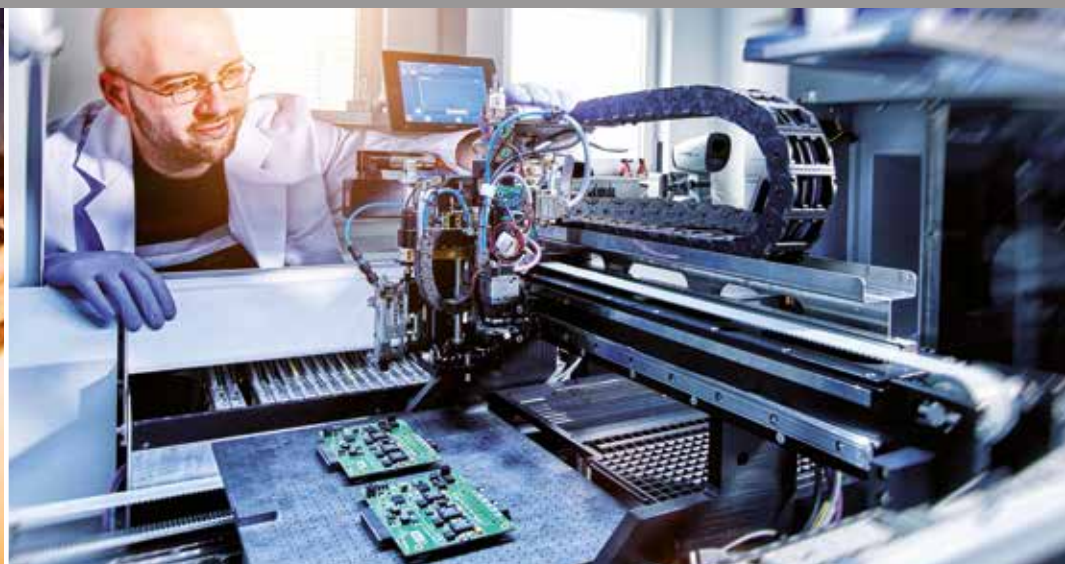
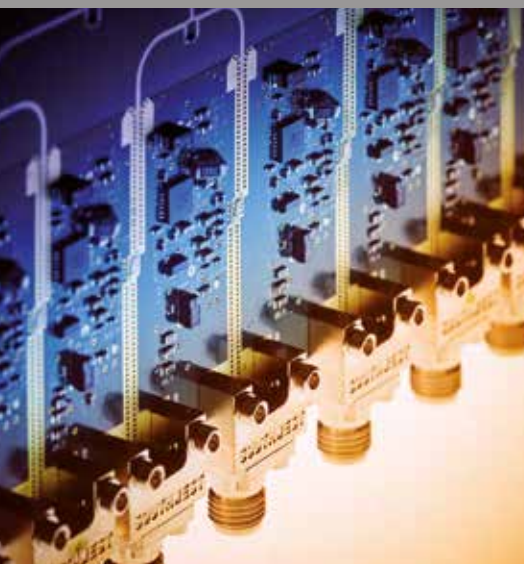

OFFICIAL GO-AHEAD FOR THE RESEARCH FACTORY FOR MICROELECTRONICS GERMANY (FMD) AT FRAUNHOFER FHR

On 6th June 2017, Thomas Rachel MdB, the Parliamentary State Secretary in the Federal Ministry of Education and Research (BMBF), gave the official go-ahead for the »Research Factory for Microelectronics Germany« in Wachtberg.

Fraunhofer FHR will invest a considerable share of the 9.3 million euro it receives from the investment program of the BMBF in the construction of state-of-the-art on-wafer and antenna measurement techniques as well as on the development of a 3D production system for rapid prototyping. With this new program, BMBF aims to network and expand national research capacities with a view to strengthening the German semiconductor and electronics industry at an international level.

Micro and nanoelectronics are decisive growth factors in the age of digitalization. For this reason, BMBF is funding the establishment of a cross-regional »Research Factory for Microelectronics Germany«. This should enhance the quality of electronic research in Germany and facilitate the provision of research services along the entire innovation chain from a single source.

With a total investment volume of approx. 350 million euro – the largest investment program for microelectronics research in Germany since the reunification – BMBF funds 13 non-university research institutions. Eleven institutes of the Fraunhofer-Gesellschaft receive a total of 280 million euro and two institutes of the Leibniz-Gesellschaft receive a total of 70 million euro.

Thomas Rachel MdB, Parliamentary State Secretary in the BMBF: »With the Research Factory for Microelectronics Germany, we are strengthening a key industry that generates high-tech growth and hence, high-tech jobs in Germany. With its new devices, Fraunhofer FHR in Wachtberg will be in a position to provide small, medium and large-sized companies with new innovations from the area of high frequency technology. Parallel to this, young scientists and researchers studying at universities in the region will have access to new possibilities.« Thomas Rachel came to Wachtberg personally

In a ceremony held at Fraunhofer FHR, Thomas Rachel MdB, the Parliamentary State Secretary in the BMBF, gave the official go-ahead for the FMD.

to confirm federal government funding in the amount of 9.3 million euro for the coming three years.

Fraunhofer FHR is one of two institutes in North-Rhine Westphalia to receive funding as part of the new research factory. Institute Director Prof. Peter Knott: »We are proud to be a part of this unique microelectronics network in Germany. The funds will allow us to invest in state-of-the-art equipment. This will enable us to create additional competencies and resources for excellent, innovative research. Our institute is further strengthening its position as an attractive partner for business and industry in the region, in North-Rhine Westphalia and in the whole of Germany.«

At Fraunhofer FHR, laboratories are currently being created for the production and testing of highly integrated and hence, compact radar systems. These are based on silicon-germanium chips and work at frequencies of up to 300 GHz. The institute is also creating two modern IEEE-compatible measurement chambers for the measurement and qualification of completed systems and antennas. The chambers will cover the frequency range from 100 MHz to 1.1 THz.

With investments in the Research Factory for Microelectronics Germany, in universities (from 2018) and in the framework program »Microelectronics from Germany – Driver of innovation for the digital economy«, BMBF will provide funding for research and innovation in microelectronics in the total amount of 800 million euro up to 2020. This is part of a package of measures for the funding of microelectronics in Germany which was initiated by the Federal Government and also includes investment support for microelectronics companies. Modern microelectronics is a prerequisite for Industry 4.0, intelligent mobility and efficient technology for the energy revolution.



Dipl.-Volksw.
Jens Fiege
Phone +49 151 613 653 67
jens.fiege@
fhr.fraunhofer.de

FROM THE INSTITUTE



WACHTBERG FORUM AND OPEN DAY

On 22nd June 2017, Fraunhofer FHR welcomed customers and partners to the annual Wachtberg Forum. Just three days later on 25th June, the institute gave visitors from the region an insight into the importance of radar research in the course of an Open Day event held on the institute's premises in and around the »ball«.

As in the years before, Fraunhofer FHR invited customers and partners to the Wachtberg Forum. The radar experts of FHR exhibited their latest radar solutions over an exhibition space of approximately 500 m²: from sensors for resource-friendly production through contact-free quality assurance and systems that enhance civil and military security to new technologies for traffic and space observation. Airborne sensors were also a focal point this year. The flying platforms of FHR – sensor-carrying drones, a gyrocopter and the microlight »Delphin« – were displayed in a separate tent. The exhibition was accompanied by lectures and presentations on the advantages of FHR technologies.

The kick-off event for the project ATRIUM, in which a simulation environment for the testing of automotive radars is created, added a festive touch to the day. One day later, within the framework of the annual Board of Trustees meeting, the trustees of the institute had an exclusive insight into the research activities at the institute and learned more about the future plans of the dual directorship after one year in office.

On Sunday 25th June, at the Open Day event, the scientists had to step down a gear or two: over the course of the day, they answered the questions posed by around 2,500 visitors and explained their complex research to young and old alike. Seeing, even in dark, foggy or smoky conditions. Detecting, even when the objects are hidden behind walls or in packages. The guests learned about the value of radar in direct conversations with the experts as well as in lectures and presentations. The big white ball, which is an eye-catcher in the Wachtberg landscape and to which admittance is normally not granted was, of course, a highlight. The dimensions of the radar system and the demonstration thereof – above all, the wind-generating rotational speed of the antenna – influenced the visitors as did the system's space observation capabilities.

*At the Open Day event 2017,
around 2500 visitors gained an
insight into the research activities
that take place in and around the
ball.*

Young explorers learned why radar is so important for space travel, how it supports environmental projects and how it can improve quality in production processes. They were also shown how radar can be used to find people in a burning house so that rescue workers do not have to spend a lot of time searching in a hazardous environment, or how radar warns drivers when other drivers, trees or pedestrians are nearby. Children who read and listened attentively were able to answer the ten questions in the children's rally and received a small prize.

The directors also used this opportunity to honor the winners of the painting and handicraft competition which was held earlier in the month. The jury had a difficult task selecting nine winners in three age categories from the large number of impressive entries. All of the winners received wonderful prizes and the first-place winners in each category were invited to visit the institute again soon after the event: in an exclusive guided tour of the laboratories they were brought behind the scenes and allowed to carry out small radar experiments.

*Dipl.-Volksw.
Jens Fiege
Phone +49 151 613 653 67
jens.fiege@
fhr.fraunhofer.de*

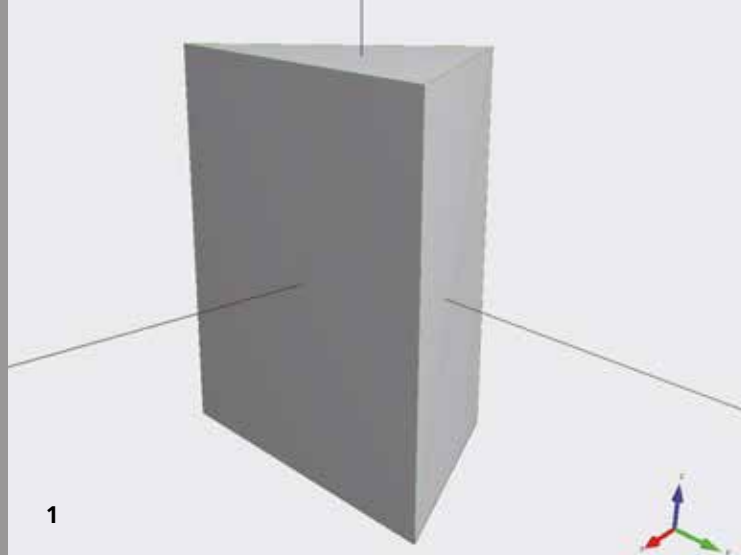

EDA-WORKSHOP »RADAR SIGNATURES & EM BENCHMARKS«

On 7th November 2017, the workshop »Radar Signatures & EM Benchmarks« took place for the first time at EDA in Brussels. The technical part of the workshop was, for the most part, organized by Fraunhofer FHR while EDA kindly provided its infrastructure for the implementation of the workshop.

For many years, software for electromagnetic (EM) modeling has been used as a standard tool in the planning of radar systems or in the development of antennas. In many applications, e.g. radar and communication, there is a noticeable trend towards higher frequencies, i.e. smaller wavelengths parallel to increased simulation software requirements. These should enhance the precision of the results, even in complex scenarios. Due to the restricted computing capacities, the RSC of a scattering body or antenna pattern was, in the past, investigated in free space in the simulation. Today, however, antenna characteristics are, for example, simulated taking due consideration of the installation site as well as electromagnetic fields which have to be very precise to be suitable for the synthetic testing of signal processing techniques.

Hence, it is becoming increasingly important that software for EM modeling is evaluated with regard to its precision and performance capability. For this purpose, the workshop »Radar Signatures & EM Benchmarks« was initiated so that the results of different simulation tools could be compared on the basis of various test examples. Task descriptions were published in the Internet a few months previous to ensure that all participants had sufficient time for their simulations.

The test examples involved different degrees of difficulty, starting with a dielectric prism in free space (Fig. 1) and progressing to a ground penetrating radar (GPR) scenario, a wind turbine (Fig. 3) and even a frequency selective structure (FSS). While the dielectric material posed the most difficulties in the case of the prism and the GPR scenario, the wind turbine was very large (1,500 wavelengths) and, moreover, it was planned to simulate rotating rotor blades with a small angle step in a subtask. In the case of the FSS scenario, the difficulty essentially lay in the fact that the individual elements were very delicate (smaller than one wavelength) with the result that frequency selectivity could only be recognized in the simulation data using an adequately fine CAD model with corresponding computation time. Measurements were also carried out for this test example at Fraunhofer FHR (Fig. 4), in which a minimum can be seen in the RCS at $\theta = 0^\circ$ and $f = 30.5$ GHz.

Most of the participants attempted to solve several test examples and, in some cases, invested an impressive amount of computing capacity. Commercial and non-commercial simulation codes from various European countries were represented. The simulation techniques used were equally diverse: although many of the problems could be solved with conventional computing systems using numerically exact methods, e.g. on the basis of the Method of Moments (MoM), asymptotic methods, for example with geometric optics (GO) and physical optics (PO), which are often just as precise as the numerically exact methods, were also used.



2



3

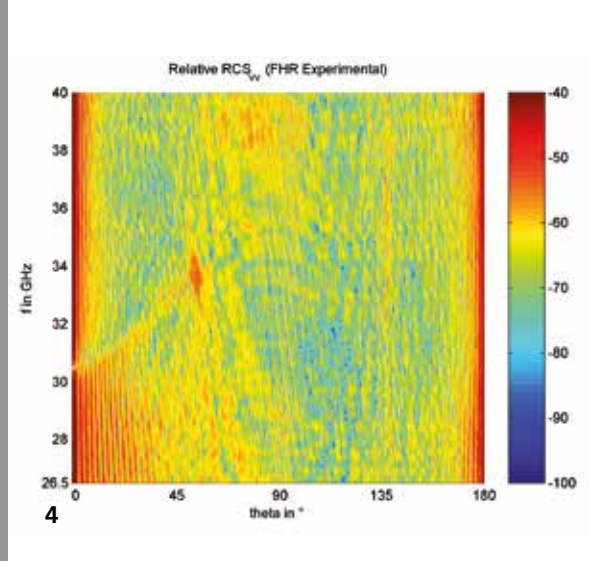

4

A comparison of the various simulation tools revealed that the fluctuation margin in the results was not as large as the typical margin a couple of years ago. It can therefore be assumed that many of these tools already reach a high precision level within the framework of the numerical possibilities. Great differences were, however, identified with regard to the required computing and storage times. Some of the simulations took several days on large multiprocessor systems with a 100 or more cores and used up several hundred gigabytes of storage space.

The scientific need for mutual exchange was clearly illustrated by the many lively result and simulation method-related discussions that took place between the experts in the course of the workshop. The workshop proved to be an ideal platform for such discussions and many of the participants requested that the event be continued in the future. The next »Radar Signatures & EM Benchmark« workshop is planned for 2019, whereby the test examples may be extended to include a measurement task.

1 Test example »Dielectric Prism«.

2 Test example »Wind Turbine«.

3 Test example »Frequency Selective Structure« (measurement object).

4 Test example »Frequency Selective Structure« (measured scattered field).



Dr.-Ing.

Frank Weinmann

Phone +49 228 9435-223

frank.weinmann@

fhr.fraunhofer.de

OVERVIEW



The premises of Fraunhofer FHR in Wachtberg with the space observation radar TIRA and the space surveillance radar GESTRA.

FRAUNHOFER FHR IN PROFILE

Fraunhofer FHR is one of the leading and largest research institutes in Europe in the area of high frequency and radar techniques. For its partners, the institute develops customized concepts, techniques and systems for electromagnetic sensors from the microwave range through to the lower terahertz range.



At Fraunhofer FHR, research activities focus on high frequency sensors for high-precision range or position determination as well as imaging systems with resolutions of up to 3.75 mm. The application spectrum of these devices ranges from reconnaissance, surveillance and protection systems to real-time capable sensors for traffic and navigation as well as quality assurance and non-destructive testing. The systems from Fraunhofer FHR are renowned for their reliability and robustness: radar and millimeter wave sensors are ideal for complex tasks, also under critical ambient conditions. They operate under high temperatures, in the presence of vibrations or in zero visibility conditions caused by dense smoke, steam or fog. Hence, radar and related high-frequency systems are also key technologies for defense and security. Fraunhofer FHR has supported the Federal Ministry of Defence (BMVg) in this area since the foundation of the institute in 1957.

The techniques and systems developed at Fraunhofer FHR are used, on the one hand, to conduct research on new technologies and designs. On the other hand, the institute – in cooperation with companies, authorities and other public bodies – develops prototypes that are designed to master currently unsolved challenges. Here, the specific focus lies on the maturity of the systems and their suitability for mass production, thus ensuring that they can – in cooperation with a partner – be quickly transformed into a finished product. Thanks to its interdisciplinary constellation, the institute has the technical expertise that is required to cover the entire value chain extending from consulting and studies to the development and production of a pilot series. The technologies used range from traditional waveguide techniques to highly-integrated silicon-germanium chips with frequencies of up to 300 GHz.

The ability to carry out non-contact measurements and penetrate materials opens up numerous possibilities for the localization of objects and persons. Due to their special

capabilities resulting from the progress in miniaturization and digitalization, the high frequency sensors from Fraunhofer FHR are an affordable and attractive option for a growing number of application areas.

Strategic orientation

Fraunhofer FHR offers its profound expertise in the business units Defense, Space, Human and Environment, Traffic, Security and Production.

The cooperation between the business unit Defense and the Federal Ministry of Defence together with its subordinate authorities is a central pillar of the activities at Fraunhofer FHR. The cooperation between the business unit Space and the German Armed Forces was also strengthened through the WRIS project (Space Identification Sensor): Fraunhofer FHR regularly supplies the German Space Situational Awareness Center of the German Armed Forces with analysis and observation data for space objects. This data is acquired with the help of the space observation radar TIRA.

In its business units Traffic, Security and Production, Fraunhofer FHR continues its successful cooperation with partners from business and industry. The business unit Environment was thematically expanded and is now called »Human and Environment«. In addition to geomonitoring systems, the unit will also focus on the development of solutions in the areas of ambient assisted living and medical treatment.

Staff- and budget development

The budget of the institute derives from several sources of finance: the basic financing from the Federal Ministry of Defence (BMVg), project financing through funds from the defense budget and revenues from the contract research area (VfA), which in turn can be broken down into economic returns, public civil revenues, EU revenues, others and basic financing from the Federal Ministry of Education and Research (BMBF). In fiscal 2017, Fraunhofer FHR generated total revenue in the amount of 34.6 million euro in the defense technology and civilian segments.

At the end of 2017, Fraunhofer FHR had a total of 336 employees. This represents an increase of 2.4% compared to the previous year. 178 are in permanent employment and 123 in temporary employment. The remaining 35 staff members are students and apprentices.

Budget development 2009 - 2017

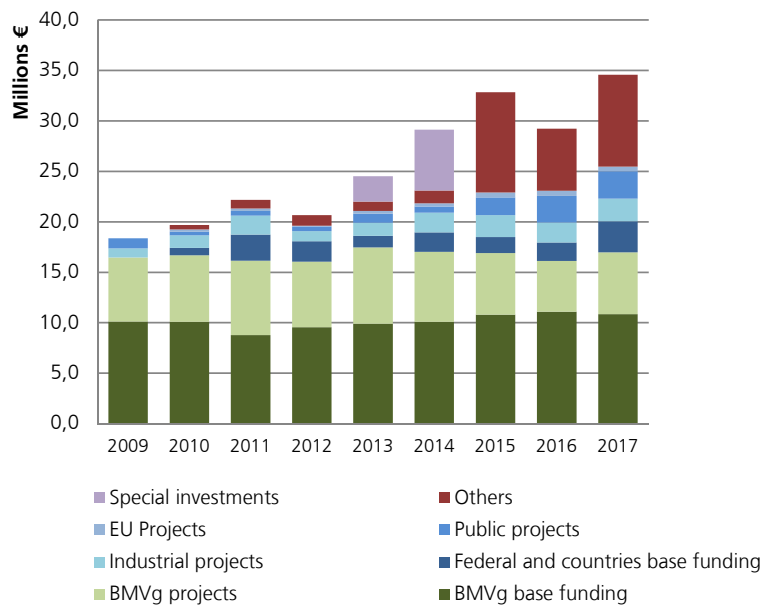

Staff development 2009 - 2017

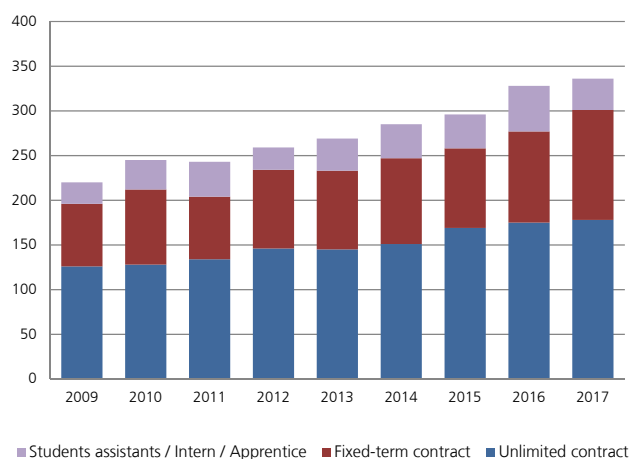

ORGANIZATION CHART OF FRAUNHOFER FHR

JULY 2018

FRAUNHOFER INSTITUTE FOR HIGH FREQUENCY PHYSICS AND RADAR TECHNIQUES FHR





Director

Prof. Dr.-Ing. DIRK HEBERLING
Phone +49 228 9435-176
dirk.heberling@fhr.fraunhofer.de

Director

IHF - Institute of High
Frequency Technology
RWTH Aachen

Security Office
Ass. jur. GLORIA POST
 Phone +49 228 9435-201
gloria.post@fhr.fraunhofer.de

Information Technology
MICHAEL BUSSMANN
 Phone +49 228 9435-211
michael.bussmann@fhr.fraunhofer.de

Workshop
CHRISTOPH PESCHEL
 Phone +49 228 9435-231
christoph.peschel@fhr.fraunhofer.de

Passive Radar and Anti-Jamming Techniques (PSR)
 Prof. Dr. DANIEL O'HAGAN
Phone +49 228 9435-389
daniel.ohagan@fhr.fraunhofer.de

Cognitive Radar (KR)
 Dr.-Ing. STEFAN BRÜGGEWIRTH
Phone +49 228 9435-173
stefan.brueggewirth@fhr.fraunhofer.de

Radar for Space Observation (RWB)
 Dr.-Ing. LUDGER LEUSHACKE
Phone +49 228 9435-200
ludger.leushacke@fhr.fraunhofer.de

Research Group
 Prof. Dr.-Ing. DIRK HEBERLING
Phone +49 228 9435-227
dirk.heberling@fhr.fraunhofer.de

Administration
 JÜRGEN NEITZEL
Phone +49 228 9435-215
juergen.neitzel@fhr.fraunhofer.de

Passive Sensors and Countermeasures
 Dipl.-Math. JOSEF WORMS
Phone +49 228 9435-216
josef.worms@fhr.fraunhofer.de

Non Co-operative Identification
 Dr. rer. nat. TANJA BIEKER
Phone +49 228 9435-634
tanja.bieker@fhr.fraunhofer.de

Techniques for Space Observation
 Dr.-Ing. LUDGER LEUSHACKE
Phone +49 228 9435-200
ludger.leushacke@fhr.fraunhofer.de

Research Group Aachen
 Dr.-Ing. THOMAS DALLMANN
Phone +49 241 80-22271
thomas.dallmann@fhr.fraunhofer.de

Finances
 Dipl.-Kff. (FH) MONIKA BRAUNS
Phone +49 228 9435-565
monika.brauns@fhr.fraunhofer.de

Passive Covert Radar
 Dr.-Ing. DIEGO CRISTALLINI
Phone +49 228 9435-585
diego.cristallini@fhr.fraunhofer.de

UWB-Radar
 Dr.-Ing. FERNANDO RIAL VILLAR
Phone +49 228 9435-770
fernando.rial@fhr.fraunhofer.de

TIRA - Radar Technology, Development and Operation
N. N.

Research Group Integrated Radar Sensors
 Prof. Dr.-Ing. NILS POHL
Phone +49 234 32-26495
nils.pohl@fhr.fraunhofer.de

Purchasing
 HARTMUT SCHMIDT
Phone +49 228 9435-331
hartmut.schmidt@fhr.fraunhofer.de

Experimental Systems
 Dipl.-Ing. (FH) JOCHEN SCHELL
Phone +49 228 9435-396
jochen.schell@fhr.fraunhofer.de

Adaptive Sensing and Perception
 Dr. rer. nat. MARÍA GONZÁLEZ-HUICI
Phone +49 228 9435-708
maria.gonzalez@fhr.fraunhofer.de

TIRA - Antenna System and Infrastructure
 Dipl.-Ing. JÜRGEN MARNITZ
Phone +49 228 9435-248
juergen.marnitz@fhr.fraunhofer.de

Research Group High Frequency Sensors und Radar Techniques
 Prof. Dr.-Ing. JOACHIM ENDER
Phone +49 228 9435-226
joachim.ender@fhr.fraunhofer.de

Human Resources
 JOHANNES NELLES
Phone +49 228 9435-526
johannes.nelles@fhr.fraunhofer.de

Passive Coherent Location
 Prof. Dr. DANIEL O'HAGAN
Phone +49 228 9435-389
daniel.ohagan@fhr.fraunhofer.de

Radar Architectures
 Dr.-Ing. STEFAN BRÜGGEWIRTH
Phone +49 228 9435-173
stefan.brueggewirth@fhr.fraunhofer.de

Space Reconnaissance
 Dr.-Ing. DELPHINE CERUTTI-MAORI
Phone +49 228 9435-290
delphine.cerutti-maori@fhr.fraunhofer.de

Sitemanagement
 THOMAS SENDER
Phone +49 228 9435-221
thomas.sender@fhr.fraunhofer.de



ADVISORY BOARD

The Board of Trustees supports our research work and advises the Directors of the Institute and the Executive Board of the Fraunhofer-Gesellschaft. Members of our Board of Trustees from industry, science and ministries:

Chairman

Prof. Dr. rer. nat. Dr. h. c. Hermann Rohling

Technical University of Hamburg-Harburg
Hamburg

Deputy Chairman

Dipl.-Ing. Gunnar W. R. Pappert

Diehl BGT Defence GmbH & Co. KG
Überlingen

Prof. Dr. Kristian Bosselmann-Cyran

University of Applied Science Koblenz
Koblenz

Prof. Dr.-Ing. Stefan Lindenmeier

Bundeswehr University Munich
Munich

Dr. Gerhard Elsbacher

MBDA Deutschland GmbH
Schrobenhausen

Prof. Dr.-Ing. habil. Otmar Loffeld

University of Siegen
Siegen

Hans Hommel

Hensoldt
Ulm

Prof. Dr.-Ing. Ilona Rolfes

Ruhr University Bochum
Bochum

Dr. Gerhard Kahl

Dornstadt

MinRat Norbert Michael Weber

Federal Ministry of Defence (BMVg)
Bonn

Dr. Holger Krag

ESA / ESOC
Darmstadt

Winfried Wetjen

OHB-System AG
Bremen

The participants of the Board of Trustees meeting on 23.6.2017 in front of the new GESTRA receive module on the institute's premises in Wachtberg: Dr. Krag, Prof. Rolfes, Prof. Schmidt, Mr. Pappert, Prof. Rohling, Mr. Hommel, Prof. Knott (Director of Fraunhofer FHR), Prof. Loffeld, Mr. Wetjen, Prof. Heberling (Director of Fraunhofer FHR), Dr. Elsbacher, Prof. Bosselmann-Cyran, Mr. Weber, Dr. Leiner (Fraunhofer Head Office).



FROM THEORY TO PRACTICE

Thanks to joint research projects as well as the long-term and close cooperation with universities and colleges in the areas of research and teaching, the scientists at Fraunhofer FHR are always in a position to integrate the latest scientific findings from the fields of radar technology and high frequency physics into new developments.

Research Group Aachen at the Institute for High Frequency Technology (IHF), RWTH Aachen

A close link exists between FHR and the Institute for High frequency Physics (IHF) of RWTH Aachen through the professors of the two Fraunhofer FHR directors. The research group of Fraunhofer FHR is located in IHF. The testing and further development of radar-based sensors for different modes of transport is one of the focal points of the research group. The research group in Aachen is responsible for the project ATRIUM, in which a radar target simulator is being developed to simplify, above all, the validation of automotive radar sensors. The group also focuses on the new application fields of radar polarimetry. This enables the extraction of information on physical scattering mechanisms that occur on the radar target and remain concealed in the absence of polarimetric data collection. The research group in Aachen pursues the strategic goal of expanding the cooperation between IHF and Fraunhofer FHR and establishing a stronger network between the institutes of RWTH Aachen and the Fraunhofer-Gesellschaft. In its own HF laboratory, the group can measure and test radar sensors, also when using complex signal forms. Through the cooperation with IHF, the research group also has easier access to other infrastructure in the locality.

Integrated Radar Sensors – Research cooperation with the Ruhr University Bochum

The possibility of integrating entire radar sensors on a chip is revolutionizing radar technology. Fraunhofer FHR has already been using integrated circuits in radar sensors for a number of decades. A special team at Fraunhofer FHR dedicates itself to the design of complex radar chips and is therefore instrumental in the development of compact and cost-effective radar systems. The cooperation in the area of integrated sensor systems was further strengthened when Professor Nils Pohl accepted his appointment to the chair of Integrated Systems at the Ruhr University Bochum.

The resource-intensive circuit design profits from the research at the university and can be seen as the final brick in the bridge towards the application-oriented research of a Fraunhofer institute. With a view to strengthening the cooperation, Fraunhofer FHR moved part of the chip design team, which is still headed by Professor Pohl, to the Ruhr University Bochum. Several joint research projects based on a shared technology roadmap have now been commenced. The first radar chips based on university research have already been successfully implemented in industrial applications by Fraunhofer FHR.

Working Group »High Frequency Sensors and Radar Techniques« at ZESS / University of Siegen

In three core areas, namely Sensor Principles & Development, Sensor Information Processing and High Level Information Extraction, the Center for Sensor Systems (ZESS) at the University of Siegen works on basic system developments with application areas in science and industry. The team is interdisciplinary



with scientists from the areas of industrial and natural science. Fraunhofer FHR has engaged in a close cooperation with the working group for more than ten years, for example, within the framework of ambitious projects relating to bistatic SAR imaging.

The research group »High Frequency Sensors and Radar Techniques« works on innovative techniques for imaging radar under the leadership of Professor Joachim Ender (Director of Fraunhofer FHR up to 2016). The application of the compressive sensing theory, which, in the presence of a structured scene, can not only achieve equivalent results with just a few measurements but can also increase the quality of the image with additional capabilities, is of special significance.

Serving as a project partner of Fraunhofer FHR in the BMBF (Federal Ministry of Education and Research) project RAWIS (Radar Warning and Information System), new results for the MIMO imaging radar relating to the monitoring of buildings in danger of collapsing were obtained. Other themes of the working group within the framework of the DFG-funded project ComSAR include the extraction of more information from ISAR images through the utilization of physically motivated representation bases, 3D imaging with an ultra-broadband sensor, also for sub-surface imaging, and innovative terahertz techniques with hybrid pseudo-random aperture modulation.

Numerous promotions are supervised and implemented by the working group within the framework of the close interaction with Fraunhofer FHR.

1 *Institute for High Frequency Technology (IHF) at RWTH Aachen.*

2 *Faculty for Electrical Engineering and Information Technology at the Ruhr University Bochum.*

3 *Center for Sensor Systems (ZESS) at the University of Siegen.*



Research Group Aachen
Dr.-Ing.
THOMAS DALLMANN
 Phone +49 241 80-22271
 thomas.dallmann@fhr.fraunhofer.de



Research Group Bochum
Prof. Dr.-Ing.
NILS POHL
 Phone +49 234 32-26495
 nils.pohl@fhr.fraunhofer.de



Research Group Siegen
Prof. Dr.-Ing.
JOACHIM ENDER
 Phone +49 228 9435-226
 joachim.ender@fhr.fraunhofer.de

INTERVIEW

»SERVING THE FRAUNHOFER IDEA«

In 2017, Fraunhofer FHR further strengthened its largest business unit so that it can respond even better to the requirements of its customers. Dr. Udo Uschkerat, an experienced and well-networked scientist, is appointed full-time spokesperson for the business unit Defense.

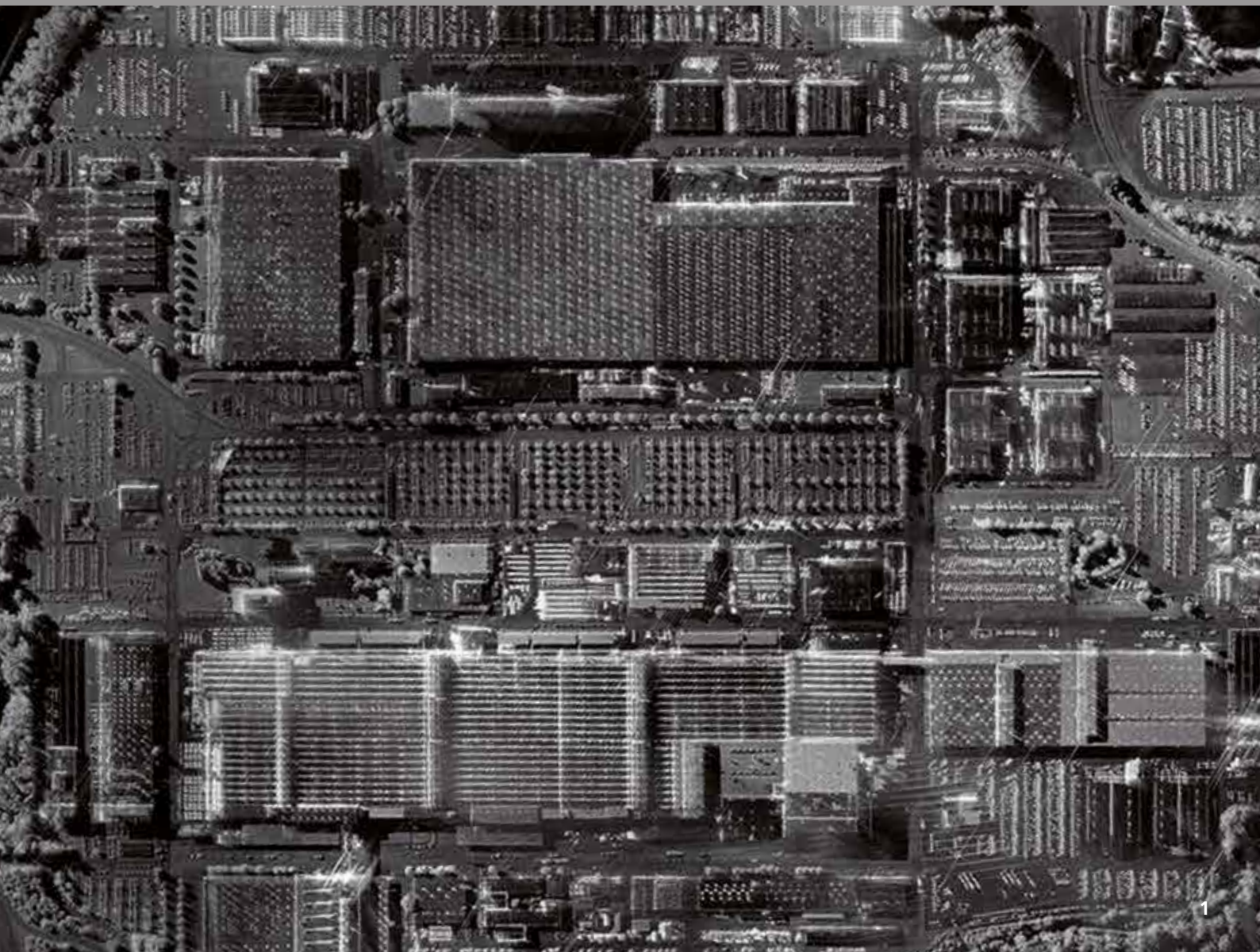

Dr. Uschkerat, you have taken on a full-time position as spokesperson for the business unit and moved away from your career as a scientist. How did this come about?

I have always worked on topics that are particularly related to defense research. I have been active in this segment for over 20 years, and have therefore been able to establish a correspondingly good network. When the Directors of the Institute decided to implement this position as a full-time job, I was proposed as a possible candidate and approached in this regard. The job sounded interesting, so I didn't hesitate for one second.

The change to another position means that you cannot continue your work in research projects. Do you miss this?

In some particular cases break off was not easy. There were a number of projects I really put my heart into. I simply had to pass on the baton. But I know the projects are in good hands. Project acquisition and customer support were things I also enjoyed doing in the past. I have taken on some new responsibilities with the new position, but I still have a lot of room to maneuver. This suits me down to the ground!

What does the position of spokesperson actually involve?

Defense research accounts for approx. 70% of our activities and is therefore our most important business field. It is therefore important to stay in close touch with the needs of the customers – even though we don't personally supply the products. But we have to be aware of the challenges that are faced by the customers of our partners, so that we can get together to develop the right solutions. I am the designated contact person and, whenever required, I also represent the institute in other committees and organizations. This also extends, of course, to representation at symposiums, conferences and exhibitions.

How important is it to stay in touch, not only with customers, but also with the scientific community?

We carry out applied research – it is therefore important to keep an eye on the latest developments in basic research. This technology watch is imperative when creating innovative ideas for new applications and technologies. Just think of quantum radar and nanotubes – and the new possibilities that will be opened up!

Do new technologies play an important role at Fraunhofer FHR?

As a Fraunhofer institute, we concentrate on applied research and development. And then there is the basic research which is carried out in universities and other non-university institutions, for example, the institutes of the Helmholtz Association. It is our job to recognize when and how new results from basic research can be developed into market-relevant products.

High frequency sensors with millimeter waves is a good example here. Thanks to the cooperation with Fraunhofer IAF and the Ruhr University Bochum, we are the technological

leader in this area. Electronic beam steering techniques for radar systems is another example. In this area, we cooperate closely with German defense companies and with GESTRA we point out how this could be implemented. In addition to new hardware technologies, new mathematical methods offer possibilities to improve or further extend the functionality of a radar system.

Which services will Fraunhofer FHR be able to offer its partners in the future?

Fraunhofer FHR has world-leading expertise in the utilization of electromagnetic waves for sensor tasks. We use this expertise to deal with new questions that arise in military and civil tasks. We give our partners access to this expertise through counseling services, experiments as well as R&D activities. For the future, we will enhance our focus on medium-sized companies in the defense sector. There is great potential here to further serve the Fraunhofer Idea – the provision of research and development services also to small companies that cannot afford it.

SAR image of the Daimler-Benz plant in Wörth.



Speaker Business Unit Defense:
Dr.-Ing.
UDO USCHKERAT
Phone +49 151 721 243 27
udo.uschkerat@fhr.fraunhofer.de

BUSINESS UNITS



DEFENSE

Smart, modular, multi-modal and compact – these are the special demands placed on future radar systems that have formed the focus of research at Fraunhofer FHR for many years already. In addition to the surveillance and reconnaissance techniques, the scientists also investigate innovative concepts for camouflaging and hardening internal radar systems as well as for jamming or deceiving enemy systems. With its extensive know-how, Fraunhofer FHR covers the entire spectrum of high frequency and radar techniques for defense purposes.

Speaker Business Unit: Dr.-Ing. Udo Uschkerat

+49 151 721 243 27, udo.uschkerat@fhr.fraunhofer.de

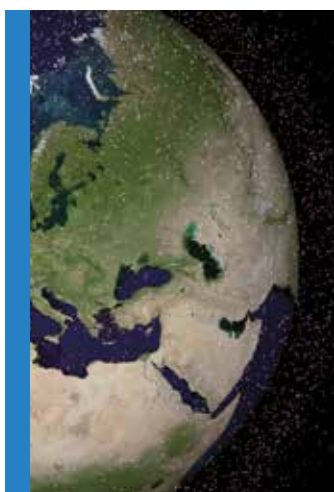

SPACE

Fraunhofer FHR is one of the leading research institutes in the area of space observation. With TIRA, the institute has a practically unique system for space surveillance. To enable uninterrupted space surveillance, Fraunhofer FHR is also currently developing GESTRA on behalf of the aerospace management of the German Aerospace Center (DLR-Raumfahrtmanagement). In the area of radar-based space reconnaissance, Fraunhofer FHR combines the entire system chain under one roof and can supply its partners with everything they require from a single source.

Speaker Business Unit: Dr.-Ing. Delphine Cerutti-Maori

+49 228 9435-290, delphine.cerutti-maori@fhr.fraunhofer.de



TRAFFIC

Radar offers numerous possibilities for applications in the air, at sea or in road traffic. Fraunhofer FHR investigates ways of leveraging this potential in various projects. The institute's partners have access to an extensive service portfolio: from technology consulting to design, construction and prototype development. Work at the institute focuses on finding efficient and prompt solutions to problems that arise during the development of a new product.

Speaker Business Unit: Dr.-Ing. Andreas Danklmayer

+49 228 9435-350, andreas.danklmayer@fhr.fraunhofer.de

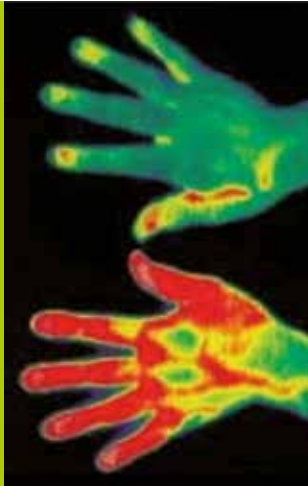

HUMAN AND ENVIRONMENT

Thanks to its precision combined with non-contact and penetration functionality, radar can open up completely new application possibilities. High-resolution imaging is also possible from large distances. The research activities of the institute also investigate application fields in the areas of health and medical technology as well as environmental- and geomonitoring.

Speaker Business Unit: Prof. Dr. rer. nat Jens Bongartz

+49 2642 932-427, jens.bongartz@fhr.fraunhofer.de



SECURITY

Research into forward-looking security solutions has always been a key issue at Fraunhofer FHR. The institute focuses on the development of compact sensor technologies which can provide emergency personnel with detailed images and information relating to the respective situation – in real time and in all weather conditions. Radar systems are therefore ideal for applications in accident scenes that are difficult to access as well as in the area of prevention for the detection of explosive devices, weapons and unauthorized objects (e.g. drones).

Speaker Business Unit: Dr. rer. nat. Jens Klare

+49 228 9435-311, jens.klare@fhr.fraunhofer.de



PRODUCTION

Innovative, customized sensors for production and industry have been a focal point at Fraunhofer FHR for many years already. The institute conducts research on compact sensors for quality control in real time. Apart from in-line capability and reliability, the price also plays an essential role in the development phase. The activities in the business unit Production aim to make an important contribution to the improved acquisition of production parameters using state-of-the-art technology with the ultimate view of creating further competitive advantages for its project partners.

Speaker Business Unit: Dipl.-Ing. Dirk Nüßler

+49 228 9435-550, dirk.nuessler@fhr.fraunhofer.de



1

AIRBORNE MULTIFUNCTION RADAR OF THE NEXT GENERATION

Reliable airborne surveillance and reconnaissance with radar requires sensors with highly flexible functionality and the best possible image quality. The radar reconnaissance systems that are currently available for utilization on flight platforms already offer a variety of operating modes and resolutions in the decimeter range. But does this mean that the feasibility limits for pulsed multifunction systems have already been reached?

Work within the framework of the project PAMIR-Ka (Phased Array Multifunctional Imaging Radar in Ka-band) reveals perspectives for novel methods and technologies for airborne, wide-area surveillance and reconnaissance in the Ka-band frequency domain.

In the final development stage, PAMIR-Ka will be a pulsed multi-channel and multi-functional radar system with synthetic aperture for ultra-high imaging and moving target indication in the Ka-band. The system is being developed as the successor of PAMIR-X system, which operated in the X-band, and will open up new technical possibilities for the frequency band between 30 and 38 GHz. The development of airborne radar systems using Ka-band technology offers many advantages compared to traditional X-band systems. More compact antennas and high frequency modules can be used in the sensor systems. Moreover, the higher bandwidth also significantly enhances the resolution of the processed image products in range direction. Combining these properties with a high-precision pulse operation in conjunction with an active

electronically steerable 2D array antenna for transmit and receive, the range can be increased by distributed transmission power generation. Further enhancement of the range resolution is possible by antenna beam tracking in the direction of flight. In conjunction with multi-channel design, enhanced radar modes can be integrated, e.g. for the better detection and location of moving targets.

2D array technology for Ka-band radar operation with synthetic aperture

Two separate antennas for transmitting and receiving are envisaged in the final stage of development. Each equipped with 48 x 8 antenna elements, the fully populated array antennas will allow very agile electronic 2D beam scanning. Combining this with a high instantaneous bandwidth of up to 8 GHz, SAR operating modes with range resolutions of less than 2 cm and resolutions in the direction of flight of 1 to 2 cm could be achieved. By appropriate thermal design, the transmit antenna array will have a high pulsed transmit power of approximately 800 watt to achieve the best possible range and image dynamic in spite of the unfavorable path attenuation in Ka-band compared to X-band.

First demonstration phase of the high-resolution SAR mode

The realization of a multi-functional radar in Ka-band requires step-by-step methodological and technological development in demonstrator phases. In the first stage of development, PAMIR-Ka is equipped with a transmitting and receiving chan-

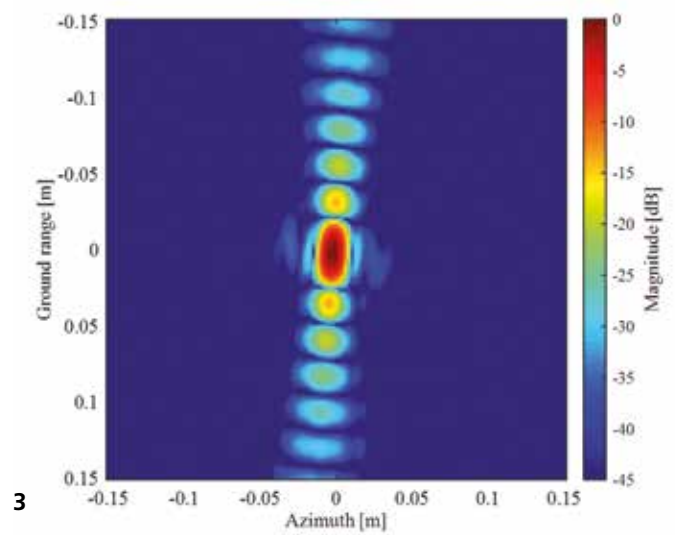
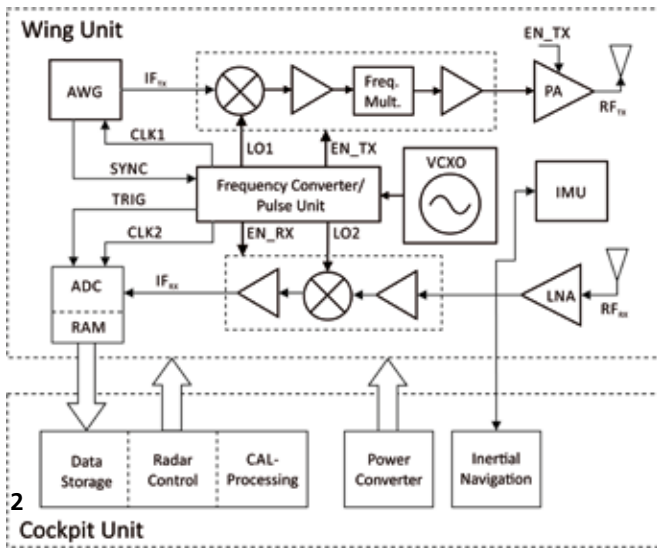

nel in a quasi-monostatic antenna arrangement. Prior to the first flight tests, the system was installed on board the FHR airplane »Delphin«. The tests aimed to verify the functionality of the system under flying conditions and investigate the relevant aspects of pulsed SAR imaging in the Ka-band.

The SAR demonstrator consists of two parts, a wing unit and a cockpit unit. The wing unit accommodates the system's front end and is installed in an aerodynamic pod. The front end comprises the antennas, signal generation, the frequency converter modules, pulse distribution and an analog-digital converter with a sampling rate of up to 20 GS/s. The pod is mounted under the wing and the antennas, which are inclined at an adjustable angle, illuminate the ground scenes. The cockpit unit consists of an inertial navigation system, a GNSS receiver, a power converter, data storage and the radar process control.

Numerous flight tests were carried out with PAMIR-Ka in 2017. The images in the stripmap mode were taken at heights of up to 800 meters above the ground with an antenna depression angle of 35°. To achieve the best possible range resolution, the complete simultaneous bandwidth of 8 GHz was used, which theoretically allows a range resolution of 19 mm. The relatively small opening of the horn antenna allows a long synthetic aperture and a correspondingly fine resolution in the direction of flight. The evaluation of the two-dimensional point spread function in the processed image shows a resolution of 9 x 20 mm on the ground (azimuth x range).

In future development stages, the system will be extended to create a multi-channel, multi-functional phased array system with Significantly increased output power and an active electronically scanned array (AESA).

- 1 FHR research airplane »Delphin« with PAMIR-Ka wing unit.
- 2 Block diagram of the Pamir-Ka SAR demonstrator.
- 3 A point target response measured at a reference target to verify the resolution.



Dipl.-Ing.
Olaf Saalmann
Phone +49 228 9435-395
olaf.saalmann@
fhr.fraunhofer.de

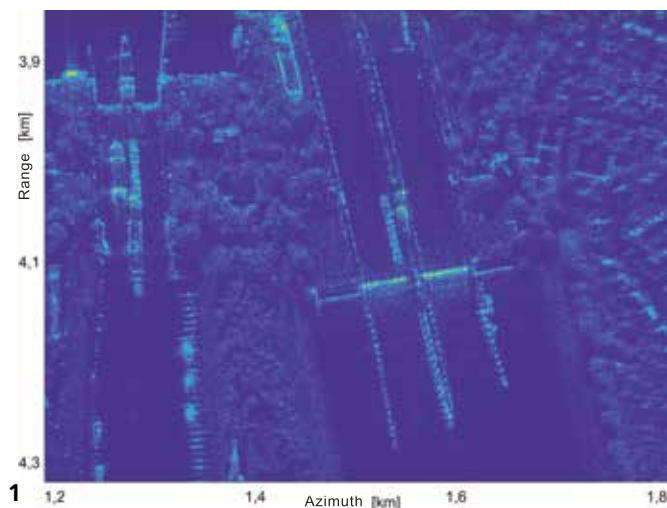

SAR IMAGING FROM INTERRUPTED MEASUREMENTS

Conventional SAR imaging techniques produce strong artifacts in the presence of incomplete measurement data. A regularization of the calculation with elastic net still allows high image quality, even when the measurement is interrupted by modern, multifunctional radar control.

Imaging the ground using airborne or space based radar systems has many advantages compared to optical methods, such as complete independence of weather and illumination conditions. A synthetic aperture radar (SAR) image is calculated from several thousand pulses of one-dimensional measurements. Therefore, the radar system is busy for a longer period of time when recording measurement data for SAR imaging, since the imaged scene has to be observed over an adequately large angle range, i.e. for a corresponding period of time, to achieve a sufficiently fine resolution. Moreover, an adequate density of equally spaced pulses is necessary for error-free SAR imaging with an acceptable noise level.

The realization of a correspondingly long, uninterrupted measurement can be problematic, particularly with regard to the growing trend towards radar systems with cognitive control. Here, a single radar antenna is used for different, alternating tasks with the result that a SAR measurement may have to be interrupted by the resource management. Other short interruptions are, however, also possible as pulses may be unusable for a number of reasons.

In contrast to optical images, radar receives an additive overlay of contributions from an extended section of the scene with each pulse. Traditional computing methods for SAR imaging – as used for Fig. 1 – sum up for every pixel of the image the measurement data with complex weights, resulting in constructive interference of the contributions belonging to the considered place in the scenery, while destructive interference almost eliminates these contributions in all other pixels. The contributions of omitted pulses are missing for all pixels and lead to the formation of stripes on individual bright objects as shown in Fig. 2a.

Artifacts caused by missing measurement data also occur in other disciplines. A look at how problems are dealt with beyond our familiar horizons is therefore worthwhile. The adaptation of these methods for SAR imaging is an important part of this work and should not be underestimated, particularly as not all of the approaches are successful. Representations – in this case, of the scene that forms the basis of the SAR image – are often reconstructed with iterative optimization methods. These try to explain the existing measurements by minimizing the receiver noise, i.e. the distance between data simulated from this representation and the original measured data. At first glance, nothing seems to have been achieved: the computing time is longer and there is hardly any change in the behavior towards missing measurement data, as shown in Fig. 2b. This technique is, however, very flexible: an optimization constraint, i.e. a regularizer which gives preference to certain image properties, can easily be added. Here, it is important that these properties correspond with the data structure, i.e. the selection of the correct regularizer is decisive.

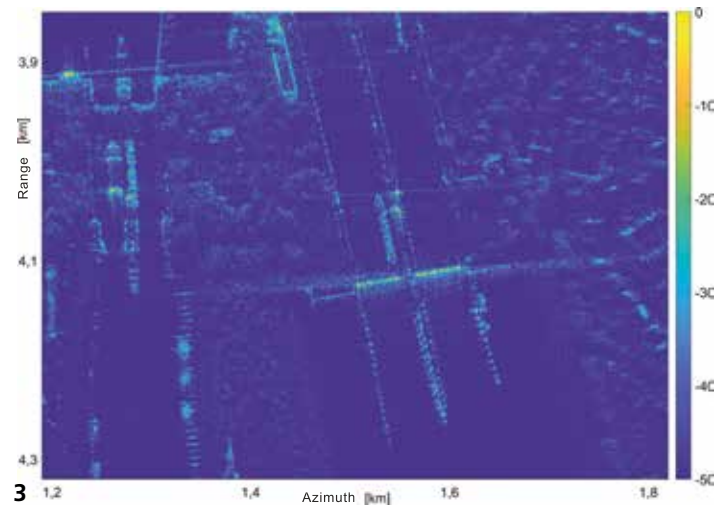
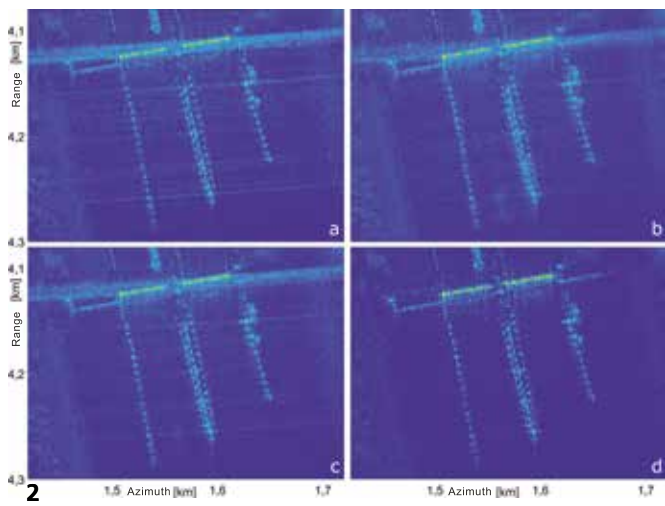

Signal processing with regularizers is by no means a new development. The Tikhonov regularization, which normally uses the energy in the reconstructed representation as a constraint, was published back in the 1970s. However, in the case of SAR imaging, this type of regularization has hardly any effect on the result, as shown in Fig. 2c. Another method, which, in the context of compressed sensing, has already been used for SAR images, uses the sum of the amplitudes of the reconstruction as a constraint. This approach prevents stripe formation in Figure 2d, but also sums up neighboring pixels. In the case of compressed sensing this is desirable, but here it contradicts the given scene and makes the SAR image appear very empty.

As both of the options tested so far display positive and negative properties, a combination of both options would appear to be the next logical step. Here, a weighted sum of both regularizers is selected as a constraint. Indeed, this approach – known in statistics as elastic net – is mathematically more complex than each of the original techniques; but it produces the SAR image in Fig. 3, which shows only a few stripes and is not extremely empty. Hence, it is suitable for SAR imaging with cognitive radar control. Nevertheless, a further improvement through more thorough analysis and more elaborate regularizers is intended.

- 1 SAR image of the lock at Brunsbüttel (Schleswig-Holstein) calculated from a complete data set using conventional computation.
- 2 Image sections of the scene in Fig. 1 computed from 64% of the pulses using different methods (see text).
- 3 SAR image computed from 64% of the pulses with a regularizer based on elastic net.



Dr. rer. nat.
 Ludger Prünte
 Phone +49 228 9435-826
 ludger.prunte@
 fhr.fraunhofer.de

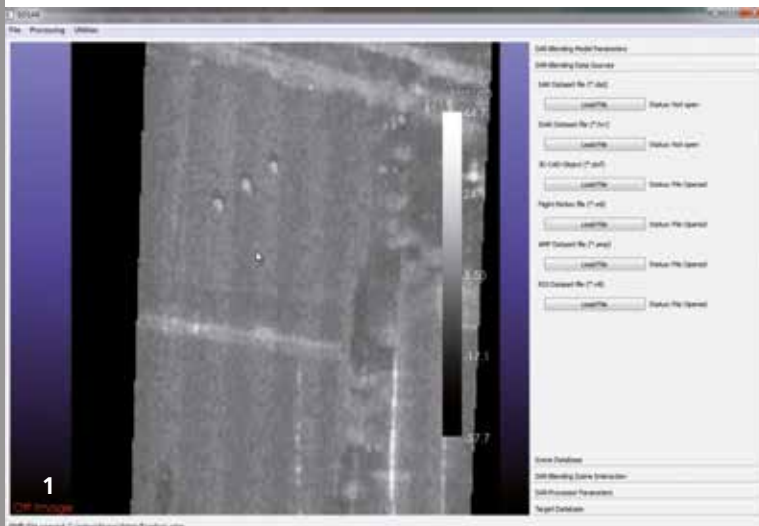

GERMAN-SWISS COOPERATION BETWEEN FRAUNHOFER FHR AND ARMASUISSE S&T

The German-Swiss cooperation between Fraunhofer FHR and armasuisse Science and Technology has already been in place for more than a decade. The two projects described in this article, namely the simulation software EOSAR and the millimeter wave airborne SAR MIRANDA-35, are part of this productive cooperation.

EOSAR – Adaptation to current SAR systems

Since 2007, Fraunhofer FHR has been working on the project »Embedding Objects in SAR Scenes« (EOSAR), which was commissioned by armasuisse S&T and the Bundeswehr Technical Centre for Protective and Special Technologies (WTD 52). Although Fraunhofer FHR has come a long way in miniaturizing airborne SAR systems and has successfully reduced the costs associated with flying over SAR scenes, certain efforts still need to be made. Depending on the objective of the SAR measurements, location and time have to be selected in accordance with corresponding criteria, such as the reflection properties of the measurement background and the prevailing climatic conditions. Vehicles, which are often interesting as measurement objects, have to be arranged in the SAR scenes. The EOSAR project aims to facilitate the subsequent integration of measurement objects into the imaged scene. To this end, mobile targets (e.g. vehicles) are measured on a turntable using inverse synthetic aperture radar (ISAR) technique. The measured data are subsequently embedded into the SAR scene, producing radar raw data, similar to the data generated in the course of a SAR flyover. After successful integration, it

is not possible to tell whether the data originate from a SAR measurement or whether they were generated with software and subsequently embedded.

The necessary embedding techniques are developed in cooperation with the Remote Sensing Laboratories (RSL) at the University of Zurich. Over the years, they have been adapted for modern sensors such as KOBRA and MIRANDA. Scientists from both nations work hand in hand on the further development of the processing chain. In Switzerland and Germany, a number of measurement objects are used as SAR and ISAR targets over longer periods in all configurations so as to ensure the comparability of the results. Regular bilateral measurement campaigns are carried out with a view to creating and expanding a measurement database which will serve as a basis for the further development and evaluation of EOSAR.

MIRANDA-35 Flight SAR – multi-channel and polarimetric

In 2010, the Swiss partner commissioned Fraunhofer FHR to develop and test an airborne SAR system that is optimized for the topographical conditions in Switzerland. This necessitated the development of a system that could cope with high altitudes and steep depression angles to minimize shading caused by high mountains and deep, narrow valleys. To achieve this, the MIRANDA system, operating in the Ka-band (35 GHz), was modified to allow a continuous transmit power of 10 W. This involved a full reconstruction of the front end and a new antenna design. The dimensions of the Swiss flying platform CENTAUR allow the realization of several receive channels for interferometric and polarimetric applications.



The sensor was tested in numerous bilateral measurement campaigns and the data were subsequently processed by Fraunhofer FHR and RSL. This paved the way for the optimization and testing of the signal processors. In addition, real-time image generation was implemented via a data link from the ground control station to the aircraft. This is a great advantage for the user of the system as the functionality of the system and the first measurement results can be monitored online. System malfunctions can be reacted to immediately and, if necessary, the measurements can be repeated without having to stop. The capabilities of the system, including real-time image generation, were successfully proven during a demonstration of MIRANDA-35 to high-ranking officials of the Swiss military. Those in attendance gained instant insight into the results of the system and a first impression of the capabilities of the system in many application scenarios.

armasuisse S&T and the RSL of the University of Zurich are competent and reliable partners of Fraunhofer FHR. The successful, continuous and synergistic cooperation with these partners leads to the creation of proven systems which are being further developed within the framework of a close collaboration.

1 SAR scene with vehicles embedded by EOSAR.

2+3 MIRANDA-35 on the Swiss flying platform CENTAUR.



Dr. rer. nat.
Anika Maresch
Phone +49 228 9435-760
anika.maresch@
fhr.fraunhofer.de



ACTIVE PROTECTION SYSTEM WITH MILLIMETER WAVE RADAR

Numerous deployment scenarios involve serious threats from hand-held anti-tank weapons which are now available in large quantities on the world market. One promising approach to counter this threat is the development and realization of active protection systems.

Due to the high impact force of armor-piercing projectiles and the present – almost hemispheric – threat situation, it is practically impossible to provide appropriate protection, especially for light, air-transportable vehicles, using conventional ballistic protection technologies. Hence, there is an urgent demand for active protection systems that are capable of detecting and combating an approaching projectile before it reaches its target. The efficiency of such a system depends on a number of factors: the reliability of detection (low false alarm rate), the quality of classification and three-dimensional localization, the processing speed of the measurement data as well as the initiation of appropriate countermeasures. The sensor, which detects the approaching threat, can also provide information on the type of the threat and supplies data which enables high-precision determination of the flight parameters (distance, flight direction, speed), plays a key role. This information must then be made available to fire control in real time. Due to its all-weather capability and its ability to penetrate dust and sand clouds, radar technology offers a number of advantages compared to other sensors (e.g. electro-optical or infrared).

Within the framework of the research project DUSIM (Dual Use Sensors in Medium Distance Range), a four-channel radar system was developed for active protection within a monitored range of between 8 m and 250 m. It operates at a frequency of 94 GHz with a low output emission of 100 mW. This makes the sensor almost undetectable for non-cooperative troops and harmless for persons in the immediate vicinity. The frequency-modulated continuous wave signal (FMCW) with a bandwidth of 1 GHz provides a high range resolution of 15 cm. The core of the DUSIM radar front end is the highly stable signal generation (Chirp Generation Board) which creates a linear frequency ramp at approx. 15.7 GHz. This is subsequently sextupled and amplified. Thanks to the four-channel receive system, the sensor can provide the precise location of the approaching projectile; here, use is made of the monopulse technique. The speed and flight direction of the projectile can also be determined using the Doppler effect. The immediate creation of a flight track after successful detection is the most important basis for targeted and precisely timed countermeasures. Clear classification lowers the false alarm rates as a distinction can be made between relevant and non-relevant targets. The front end shown in Fig. 1 measures 200 x 180 x 230 mm³ and weighs approx. 3 kg.

The system was successfully tested under realistic conditions in several measurement campaigns. Tests were carried out with small caliber ammunition as well as with armor-piercing projectiles (e.g. RPG 7). Examples of the results are presented in Figures 2 and 3. In 2016 and 2017, additional tests were carried out in the centrifuge facility of WTD 91 in Meppen. Here, various threats were moved in a reproducible manner

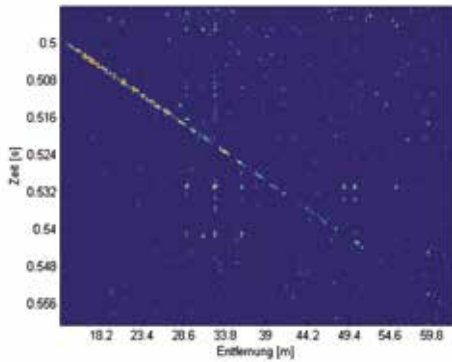

2

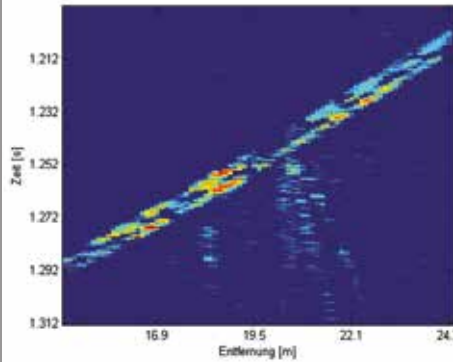

3

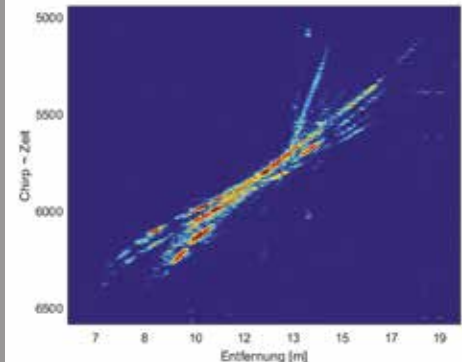

4

on a circular track, a section of which was tangentially illuminated by the radar. Due to the high repetition rate, it was possible to record approx. 700 individual measurements of the used missiles (11 different threats). In this way, the various radar signatures of the different projectiles used can be examined in a cost-efficient manner in very little time without elaborate shooting tests. Moreover, thanks to the large volume of measurement data, it was also possible to make statistical statements relating to the observed objects. Figure 4 shows a section of a typical centrifuge measurement.

The successful measurements and good results show that the further development of the DUSIM radar sensor for utilization in other active protection systems is indeed worthwhile. Improvement potential does exist, particularly in the area of signal processing, e.g. localization and classification of objects. An increase of the output power (to a realistic value of 1 W) could also extend the coverage area of the radar system.

- 1 *DUSIM – four-channel radar front end with an output power of 100 mW at 94 GHz.*
- 2 *Trajectory of a small caliber projectile (MG3 7.62 x 51 mm).*
- 3 *Section of the trajectory of an RPG. The bow and stern of the rocket can be distinguished.*
- 4 *Trajectory of a missile in the centrifuge facility of WTD 91 in Meppen. Two scattering centers can be seen on the target object and further scattering centers with a lower velocity can also be seen on the centrifuge itself.*



Dr. rer. nat.
Michael Caris
Phone +49 228 9435-353
michael.caris@
fhr.fraunhofer.de

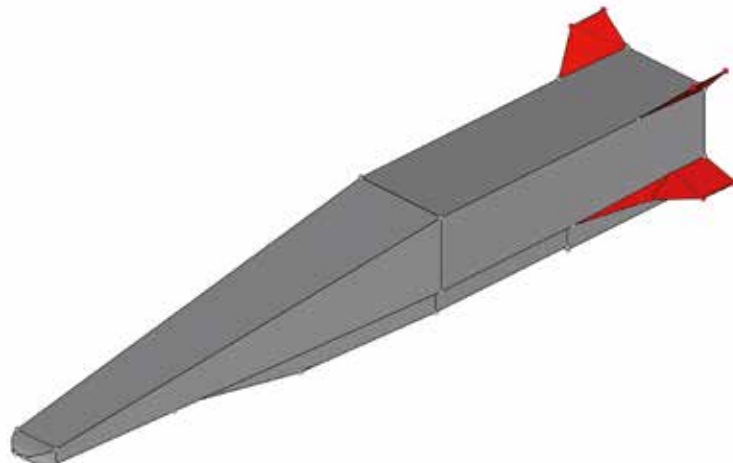

1

DEFENSE AGAINST HYPERSONIC MISSILES

Ballistic missiles pose a worldwide threat. NATO and the European military forces have already taken defense measures and further defense capabilities are being developed.

Missiles that ascend to low earth orbit can reach a supersonic speed faster than 6 Mach (six times the speed of sound, approx. 2 km per second). Such speeds, otherwise known as hypersonic speed, are normally only reached outside the dense layers of the Earth's atmosphere. New types of missiles are, however, continuously being developed and the capability to carry out suborbital flights at these speeds is currently under development in several countries.

Scramjet propulsion is a technology now used in the development of such hypersonic missiles. In the past, this technology was used solely for anti-aircraft missiles, but recently there have been reports (Zirkon, Brahmos II, X-51) that this form of propulsion has been further developed for hypersonic cruise missiles (HCM).

One further development combines a ballistic rocket with trajectory control using wing flaps with the effect that such missiles do not have to follow a ballistic trajectory but can also carry out so-called »pull-up« maneuvers at the end of the normal ballistic trajectory. These missiles are known as hypersonic glide vehicles (HGV). One special feature arising from this alternating ascent and descent is that the target can drop below the radar horizon thus making detection and tracking much more difficult. Both of the missile technologies referred to above pose new threats that have to be detected by air surveillance radar. The high speeds greatly reduce the reaction time for

countermeasures. For this reason, existing radar systems have to be examined with regard to their detection speed and tracking precision.

The radar sensor tasks that require examination can be categorized as follows:

- Radar components: transmitter, receiver, antenna gain, beam scanning
- Assumption of target characteristics: radar cross section, maneuverability, speed
- Radar algorithms: search method, detection method, tracking method

While the radar components are specified through the capabilities of the defense industry, a research institute can, in particular, investigate the radar cross section (RCS) of the target and the compatibility of radar algorithms relative to the speed and maneuverability of the target.

Radar components

The expansion of the maximum radar range fundamentally depends on the possibilities that exist to further increase the transmit power and to develop more sensitive detectors. Current developments focus, above all, on making inertia-free beam steering available for radar systems that also have a high transmit power. Fraunhofer FHR carries out important research on the utilization of electronic beam steering for ground radar systems.

RCS-Simulationen: 470 MHz

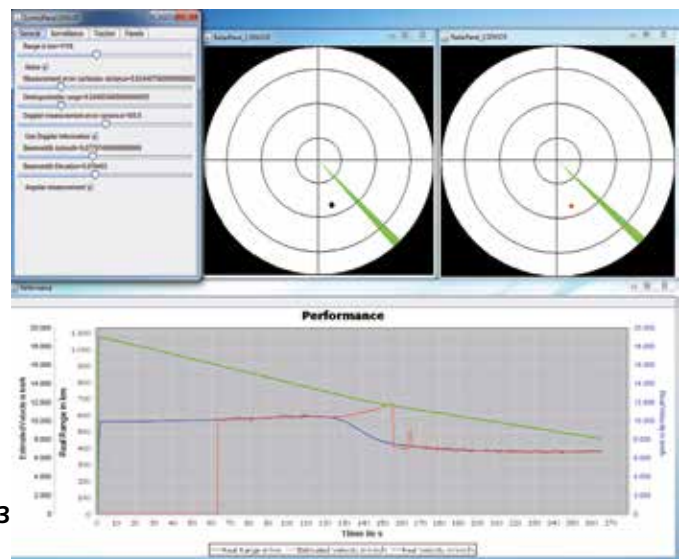
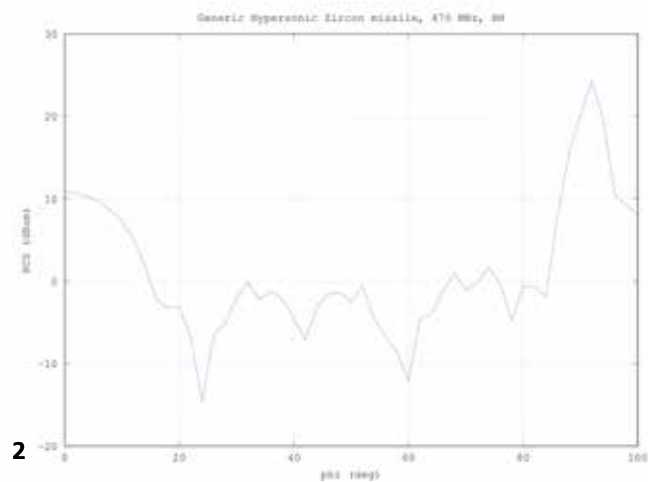

Radar cross section

To calculate the RCS of a foreign target, a geometric model (CAD model) is needed which, with the help of standard CAD software, can be established by using drawings and/or photos that closely correspond to the original target. This geometric model then serves as input for simulation programs for electromagnetic modeling (Fig. 1).

Fraunhofer FHR has many years of experience in the area of electromagnetic modeling and has implemented a range of simulation tools that are described in various publications and widely accepted in the scientific community. These techniques allow the calculation of the backscattered field of an incident electromagnetic wave at any required target model (Figure 2). The results are needed to assess the suitability of a radar system for this target category. Any special effects of the electromagnetic fields on the target object can also be investigated.

Radar algorithms

The development of radar algorithms not only requires mathematics but also the development of a radar simulation that is capable of testing the algorithms. This simulation can take place at various levels. Here, we are looking at a simulation level that uses established formulas and, for this reason, does not, for example, offer a detailed simulation of the behavior of electronic components. Moreover, various trajectories and target maneuverability can be observed.

In case a radar system does not yet exist, the radar simulator can be used to make an initial estimation of the performance that each radar component must fulfill to successfully detect and track the target category under investigation. If the radar components are known, a simulator can be used to work on the target search and target tracking algorithms. In particular, the precision of target tracking can be greatly improved when the limits of the target with regard to mobility and maneuverability are known. The scientists at Fraunhofer FHR are working on new intelligent target search, detection and tracking techniques. By predicting target maneuvers and through the effective distribution of resources, targets which have dropped below the radar horizon can quickly be found again for track re-initiation. The latter poses one of the new challenges associated with extending the capabilities of defense systems to contend with hypersonic glide vehicles.

- 1 Generation of a CAD model based on geometric assumptions relating to the target.
- 2 Result of the calculation of the RCS, here, over an angular range of 100 degrees.
- 3 Simulation-based investigation of the suitability of a radar system and the target tracking algorithms.



Dr.-Ing.
Udo Uschkerat
Phone +49 151 721 243 27
udo.uschkerat@
fhr.fraunhofer.de



DVB-S2-BASED PASSIVE RADAR IMAGING

Reliable and high resolution radar imaging play an increasingly important role in the identification of non-cooperative targets in military scenarios. Passive radar guarantees at the same time also discreet surveillance. SABBIA, a system that was developed at Fraunhofer FHR, uses the signals that are sent by satellites (DVB-S2) to image non-cooperative targets. SABBIA is able to achieve resolutions below 2 meters and also allows operation with different orthogonal polarizations.

Passive radar systems are gaining in importance in the area of defense technology. Apart from the conventional air-space surveillance systems, a number of new reconnaissance techniques were developed in the past years. These include the highly rated passive radar imaging techniques SAR and ISAR. The image capability of such radars normally depends on the wavelength and the instantaneous signal bandwidth of the illuminator of opportunity used as transmitter. Conventional transmitters in the VHF and UHF frequency ranges greatly restrict the available signal bandwidth. Digital TV satellites (DVB-S2), on the other hand, which are operating in the Ku-band, allow the utilization of a higher bandwidth. Range resolutions of just a few meters can be achieved and this is a very important prerequisite for imaging techniques. In addition, the utilization of DVB-S2 for military applications offers two significant advantages. For one, the DVB-S2 signals offer high illumination and are therefore available in remote areas and open seas. Secondly, a deactivation of satellites in the event of war is much more difficult than is the case with ground-based transmitters. One disadvantage of DVB-S2-based passive radars is the low power spectral density at the

receiver as this requires the utilization of high gain antennas and long integration times when processing the signals. Long integration times are, however, not an important disadvantage for passive target imaging as these are traditionally required from the ISAR technique to achieve a high resolution capability in the cross-range dimension.

Fraunhofer FHR developed the experimental system SABBIA to allow passive radar imaging for non-cooperative airborne and maritime targets. Here, the DVB-S2 signals that are transmitted from geostationary satellites, e.g. the signals from the satellite ASTRA 19.2°E, are exploited. SABBIA basically consists of two structurally identical receive modules – a reference module and a tracking module – as can be seen in Figure 1. The reference module acquires the direct satellite signal which illuminates the scene and the tracking module is used to receive the target echo. After the analog-to-digital conversion, both received signals are recorded with high-speed data recorders. The receive unit comprises an 85-centimeter dish antenna, a custom designed antenna horn and a Quattro LNB. This has a low noise figure and also has an internal low phase noise oscillator as well as an external 10 MHz reference input. Both receive modules are equipped with a GPS-IMU (Inertial Measurement Unit) so that they can receive precise information about position and antenna pointing direction. The LNB can demodulate DVB-S2 signals simultaneously in horizontal and vertical polarization as well as in both the low and the high band. This enables fully polarimetric operation of the system.

Field tests were carried out with SABBIA in 2017 within the framework of the MAPIS (Multi-channel passive ISAR imaging for military applications) project of the EDA (Cat. B). In the



2

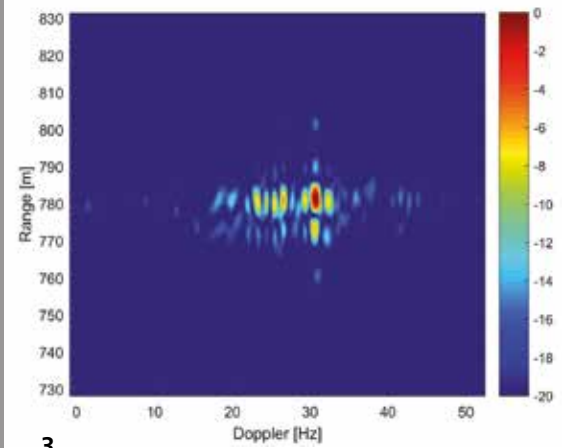

3

course of the tests, the military vessel Porpora (Figure 2) was measured and the resulting signal is then processed to obtain an ISAR image (see Figure 3). The bistatic geometry and the alignment of the vessel allow the imaging of the target from a top view (bird's eye perspective). Here, the vessel echo is squeezed in a single range cell, as a higher range resolution could not be achieved due to the low signal bandwidth. The cross-range direction (shown in Fig. 3 as Doppler axis) is, however, well imaged. This result can be used to derive the size of the target. This information is essential for detection and classification of the target.

- 1 *SABBIA system.*
- 2 *Cooperative target Porpora ship.*
- 3 *DVB-S2-based ISAR-Image of Porpora ship [dB].*

*Dipl.-Ing.
Iole Pisciotano
Phone +49 228 9435-784
iole.pisciottano@
fhr.fraunhofer.de*



CRYOGENIC PHASED ARRAY RADARS FOR SPACE SURVEILLANCE

In the future, the utilization of cryogenic techniques should greatly enhance the sensitivity of phased array radars. Scientists at Fraunhofer FHR have taken on the great technical challenge of developing efficient cooling measures to reduce system noise temperature.

The utilization of radar technology for space surveillance to determine the position of debris particles and satellites in near-Earth space is growing in importance. Active phased array radar systems play a significant role in the area of radar surveillance. The electronically steerable beams facilitate the simultaneous surveillance of various cardinal points as well as high, inertia-free beam agility and therefore allow the fast and precise tracking of moving targets.

A high signal-to-noise ratio (SNR) is very important for the detection of space debris. This parameter depends on the intrinsic noise temperature of the individual receive channels. If this is too high, weak signals can no longer be distinguished from noise and will therefore remain undetected. For this reason, one of the next challenges in future phased array projects for space surveillance lies in the technical realization of efficient cooling measures for the individual receive channels. Particularly in the area of space debris detection, it is essential that the SNR be improved through the reduction of the system temperature while using a defined equivalent isotropic radiated power so that even the smallest particles can be detected in low Earth orbit (LEO).

In 2017, the aerospace management of the German Aerospace Center (DLR-RFM) commissioned the ARB department of Fraunhofer FHR to investigate cryogenic receivers for phased array antennas in general, with a particular focus on systems that are similar to the GESTRA system. This led to the creation of a new research area at Fraunhofer FHR.

Present technical situation

In radio astronomy, cryo-cooled receiver to reduce the system temperature in single-pixel detectors, such as the 100-meter parabolic reflector Effelsberg, has already been established for decades. Due to mechanical and high-frequency challenges, techniques for the reduction of receiver noise in phased array systems are still in the very early stages of development. The research now conducted at Fraunhofer FHR focuses on the design and optimization of various approaches for the cryo-cooling of phased array systems. A cost-benefit analysis is also carried out to shed light on economic aspects.

As the largest share of the system noise temperature is generated by the first amplifier (Low Noise Amplifier, LNA) in a receiver chain, the primary focus lies on the effective reduction of inherent noise by cooling the first amplifier stage.

Freezing improves detection sensitivity

When not cryo-cooled the first amplifier in the receiver chain is in an environment with room temperature (290 K, corresponds to 20°C). Research activities now focus on cooling the first amplifier stage to below 20 K (-253°C) with gaseous

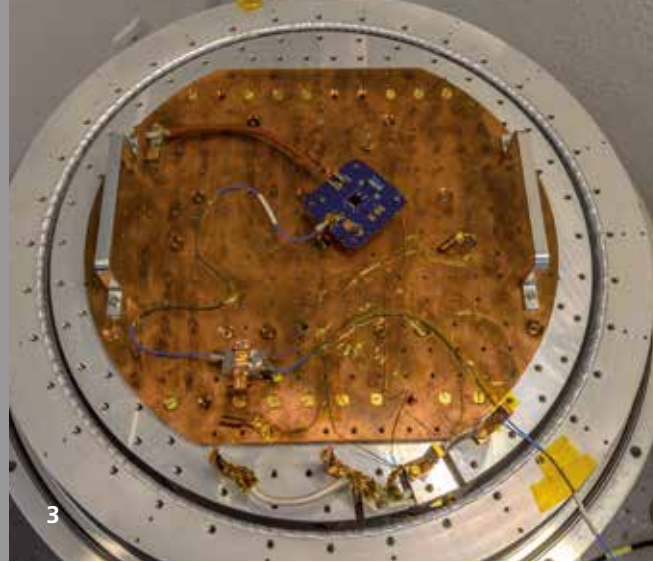

helium to achieve system temperatures below 50 K (-223°C). The radar equation shows an improvement in the signal-to-noise ratio of approx. 3 dB, with the result that objects with a radar cross section of half the size can be detected in orbit.

Experiments at up to -269°C

Some of the initial – internally funded – project activities involved the creation of a suitable infrastructure. Appropriate measurement chambers that allow the safe handling of inert gases (e.g. helium) and liquid nitrogen were constructed.

Various tests will be conducted in these measuring facilities to investigate which low-noise amplifiers offer the best performance when cryo-cooled and how the measuring techniques for temperature monitoring can be optimized. The biggest challenge here lies in the mechanical development of vacuum-tight, stable and high frequency permeable experimental environments parallel to the achievement of an optimal thermal connection between the cryo-cooler and the first amplifier stage. In cooperation with one of the leading companies in the areas of cryogenic engineering, a dewar was developed specifically for this purpose. With the dewar, the challenging high frequency and material experiments can be carried out at temperatures of up to 4 K (-269°C).

On successful completion of the first phase, attention will turn to the realization of a highly sensitive, phased array-based space surveillance radar. The implementation of a cryo-cooled receiver system for radar applications would be a milestone in the improvement of receiver sensitivity. This important technology would also have the potential to take many other research areas a decisive step forward.

- 1 Dewar for the measurement of electronic components (height: 840 mm diameter: 620 mm).
- 2 Vacuum-tight flange on the measuring dewar with mounted, vacuum-tight, four-pole DC inlets.
- 3 Experimental platform cooled to 4 K, located inside the measuring dewar.



Dr. rer. nat.
 Nadya Ben Bekhti
 Phone +49 228 9435-768
 nadya.ben.bekhti@
 fhr.fraunhofer.de



CHARACTERIZATION OF THE SMALL-SIZE SPACE DEBRIS POPULATION WITH TIRA

Small objects just a few centimeters in size can damage or even completely destroy satellites. The space observation radar TIRA measures the population of small particle space debris on a regular basis. The results obtained from the radar data are used to calibrate and validate models of the space debris environment.

The number of space debris has grown exponentially since the start of space exploration back in 1957. Debris from collisions and explosions, rocket bodies, disused satellites and other space objects is orbiting the Earth and poses a risk for active space systems. Due to the high relative speeds, a collision with an object just one centimeter in size could prove fatal for an active satellite.

Currently, objects larger than about 10 centimeters in size can be detected, tracked and catalogued from the Earth using radar systems and telescopes. Smaller objects and objects in highly elliptical orbits are, however, much more difficult to detect and track. These objects can not be catalogued at present, i.e. the location of these objects, which are potentially very dangerous for satellites, at a particular time is not known. Hence, information relating, at least, to the distribution of these objects in space is very important.

Since its completion, the space observation radar TIRA has been the leading system in Europe for the observation of space objects. Due to its extremely high sensitivity, TIRA can measure the weak backscatter signals of the smallest particles of space

debris. In this way, small objects just two centimeters in size can be detected at a distance of 1,000 kilometers. This high sensitivity is achieved, in part, through the large gain of the highly dynamic 34-meter antenna.

Due to this capability, TIRA and Fraunhofer FHR have participated in regular international measurement campaigns (the so-called beam-park experiments (BPE)) to measure the small-size space debris population and record its statistical distribution. These measurement campaigns are coordinated by the IADC (Inter-Agency Space Debris Coordination Committee) and take place every two years usually. It is important that such measurement campaigns are carried out on a regular basis to ensure that changes in the small-size space debris population can be monitored. The space population in Low Earth Orbit (LEO) is particularly dynamic: debris particles are created through explosions and collisions. New satellites and other pieces of space debris (e.g. rocket upper stages) enter space and other objects disappear from space due to atmospheric drag and re-entry into the Earth's atmosphere. The results of these sample observations are important sampling points for space debris environment models, such as the ESA's MASTER model (Meteoroid and Space-Debris Terrestrial Environment Reference) and allow the calibration and validation of these models.

During a BPE, the antenna of a participating radar sensor is parked in a selected direction and radar data is recorded over a period of 24 hours. The rotation of the Earth ensures that the radar has observed a closed volume at the end of the 24-hour period. Different orbital regions can be recorded, depending on the antenna's line of sight. The antenna is, for example, parked

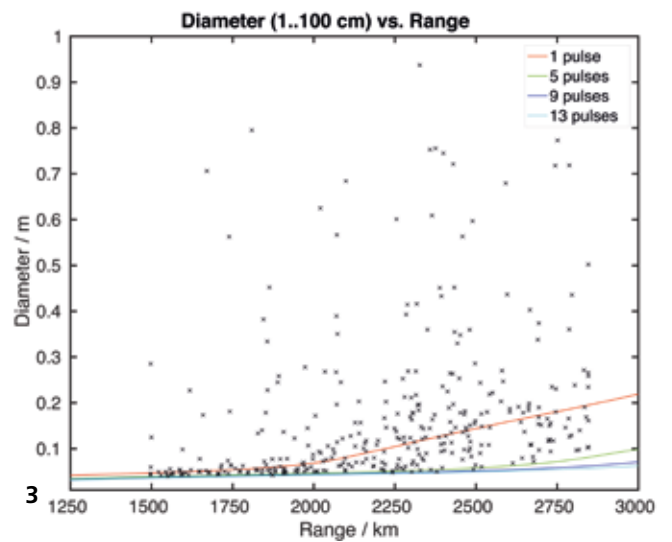
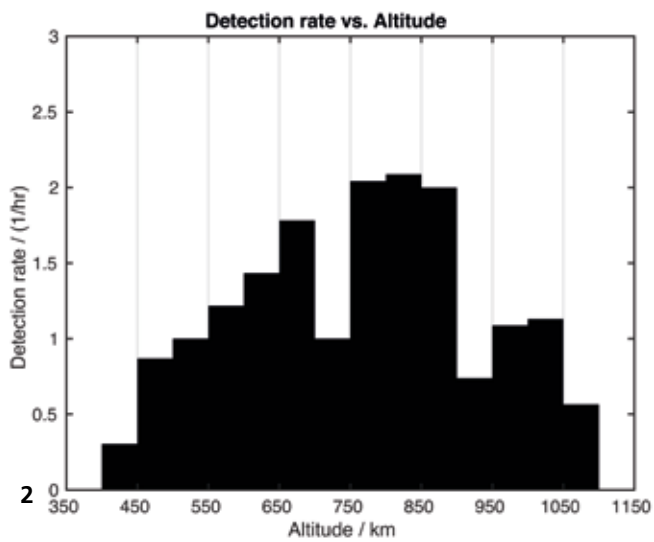

in an easterly direction for an east-staring BPE. In the case of a south-staring BPE, the antenna faces south with a low elevation angle. With this geometry, it is possible to investigate the debris population in orbits with a low inclination. The radar data provides a lot of important information about the detected objects. The size of an object can, for example, be estimated on the basis of the radar cross section. The orbital height and orbital inclination can also be estimated under the assumption that the orbit is circular.

A south-staring BPE was carried out for the first time in December 2015. Three American radar systems also participated in this IADC measurement campaign: the HUSIR radar (Haystack Ultrawideband Satellite Imaging Radar), the Cobra Dane Radar and the Goldstone Radar. A joint report on the recorded space particles and their distribution over the estimated orbital parameters was compiled and is currently being evaluated for the calibration and validation of space debris environment models. Figures 2 and 3 show some results achieved with TIRA. In Figure 2, the detection rate is shown according to the orbital height of the detected space debris. The estimated size of the particles over distance is shown in Figure 3. This project was funded by the ESA/ESOC.

- 1 *The heart of the TIRA system: the 34-m parabolic antenna.*
- 2 *Detection rate over the orbital height.*
- 3 *Size of the detected space particles over distance.*



*Dr.-Ing.
Delphine Cerutti-Maori
Phone +49 228 9435-290
delphine.cerutti-maori@
fhr.fraunhofer.de*

*Dr.-Ing.
Jens Rosebrock
Phone +49 228 9435-656
jens.rosebrock@
fhr.fraunhofer.de*

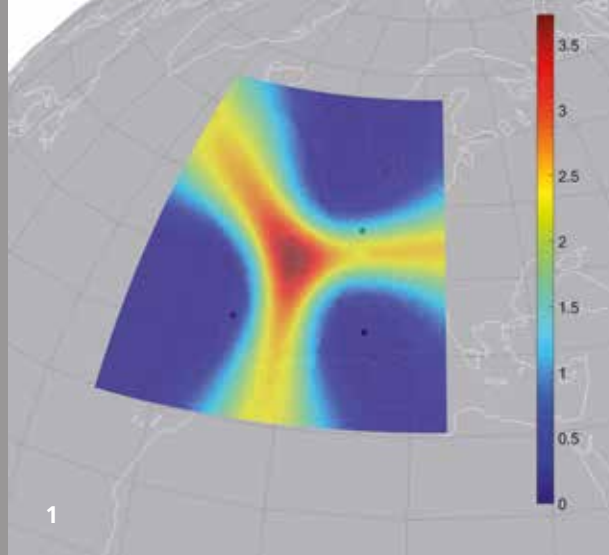

SURVEILLANCE OF NEAR-EARTH SPACE WITH A RADAR NETWORK

With the support of the aerospace management of the German Aerospace Center (DLR-RFM), Fraunhofer FHR is working on concepts for the surveillance of near-Earth orbit using a network of radar systems. Scientists analyze the efficiency of various concepts and devise potential solutions for the anticipated technical challenges.

Modern society relies, to a growing extent, on the utilization of near-Earth space, e.g. for satellite-based communication services and Earth observation. The volume of space debris continues to grow unabated, partly due to this intensive utilization. Contributors to space debris include the disused upper stages of carrier rockets, satellites that no longer function and residue from rocket fuels and small objects that have become separated from satellites. Two particular events, namely the collision between the two satellites Iridium 33 and Cosmos-2251 in 2009 and the intentional destruction of a satellite in 2007 each led to a large increase in the debris population.

Space debris jeopardizes the utilization of near-Earth space. A collision between even a relatively small debris particle and a satellite can lead to the destruction of the satellite, due to their high speeds. This problem, among others, has in recent years made clear the importance of gaining knowledge pertaining to the population of satellites and space debris, as it can be used to plan evasive maneuvers for satellites to reduce the risk of a collision.

It is in this context, that the aerospace management of the German Aerospace Center (DLR-RFM) commissioned Fraunhofer FHR with the development of the GESTRA system. With GESTRA, Germany will, for the first time, have the ability to carry out a large-scale, radar-based search for debris particles and satellites in near-Earth space (near-Earth orbital paths), and it will also be possible to determine the orbits of detected objects.

At Fraunhofer FHR, the scientists are also looking beyond the GESTRA system to a time in the future when a network of radar systems will jointly search near-Earth space for debris particles and satellites and determine the orbits of these objects. This takes place within the framework of the DLR-RFM-funded project »A Network of Radars with Array Antenna for Space Surveillance« which extends into 2019.

Here, the scientists investigate a number of overarching questions, such as »Should the radar systems in the network be positioned near to each other, i.e. within a distance of a couple of hundred meters?«, this type of network is known as a 'local radar network' or »Would it be better to distribute the radar systems over several hundred or even thousand kilometers?«, researchers refer to this as a 'radar network of medium extent'. Both approaches have their own advantages: in a local network, the data of the receivers can, due to their physical proximity, be combined in a very elegant manner so that even objects with a small radar cross section can be detected. A network of medium extent, on the other hand, facilitates the acquisition of data from different angles. It is expected that the combination of this data will allow for more

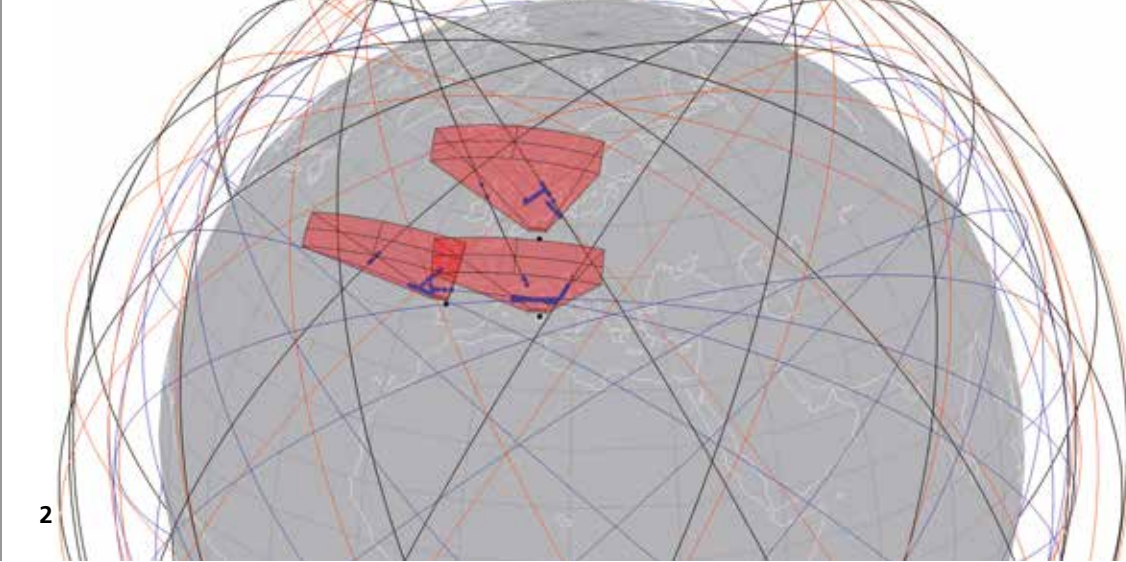

precise measurements of position and speed.

The researchers carry out performance tests to compare the respective strengths of the different network types. Here, they model the typical radar-related characteristics of a radar network, such as detection probabilities and estimation accuracies. The most important factor, however, is the orbit determination ability. For this reason, part of the project is dedicated to assessing the orbit determination accuracy of various radar network concepts with to the goal of identifying the most promising approach.

Figure 1 shows a result of these performance tests. The figure shows the extent to which an object can – based on certain assumptions – be better detected at a height of 700 km with an exemplary radar network when bistatic signal paths are also evaluated together with the three monostatic signal paths. Black dots indicate the locations of the individual radar systems in the network. Figure 2 shows the coverage area of the same network and simulates target detections which serve as input variables for orbit determination.

In addition to the performance tests, the scientists also carry out initial investigations to identify technical challenges that may occur. In particular, they closely examine the synchronization of the subsystems, the design of the data processing in the local network and the evaluation of bistatic signal paths in a medium-sized network.

1 *Reduction of the radar cross section (in dB), from which objects can be detected through the additional utilization of bistatic signal paths in the presented network.*

2 *Transmit fields-of-view, orbits and detection points for three exemplary objects.*

SPONSORED BY THE



Federal Ministry
for Economic Affairs
and Energy



Dr.-Ing.

Robert Kohlleppe

Phone +49 228 9435-392

robert.kohlleppe@

fhr.fraunhofer.de



DEMONSTRATION OF A SOLID-STATE RADAR FOR MARITIME NAVIGATION

Maritime areas cover 71% of the Earth's surface and carry over 90% of the world's trade, resulting in a need for dependable sensing capabilities as a tool for the safety and the international coexistence of maritime activities. For this reason, Fraunhofer FHR has undertaken investigations to further develop radar technologies for maritime navigation.

Especially in non-cooperative situations or in case of emergency, maritime situational awareness is mostly depending on remote sensing technologies. In particular, maritime radar is a fundamental tool to gain real-time awareness of the surrounding of a vessel and thereby improve safety on the high seas. Particularly in the context of long-range S-band radars, legacy architectures based on magnetrons are still largely adopted. While time-tested and reliable, these units are normally based on incoherent processing of magnetron pulses (with emissions on the order of tens of Kilowatts) and require yearly maintenance. Solid-state power amplifiers, on the other hand, allow generation of waveforms with a known phase, granting more effective signal processing and therefore lower emission levels. To showcase the suitability of the solid-state approach, a new S-band portable radar demonstrator has been developed. The challenge in setting up an S-band field-ready demonstrator essentially lies in the operational frequency and the required angular resolution. Working at 3 GHz implies dealing with notable antenna size and weight, which in turn scales up the logistic and safety aspects. With an antenna weight of 260 kg (a commercial 12 foot slotted waveguide scanner plus gear-box) and the need for an electro generator (about

150 kg) using a trailer has been identified as the most practical solution (Fig. 1).

Aiming at validating within actual operating conditions multiple hardware choices and different processing strategies, the current prototype features a coherent zero-IF architecture with modular and reconfigurable processing chain. Although depending on specific calibration techniques to prevent sensitivity losses due to impairments among baseband channels, direct conversion can benefit from higher waveform oversampling without requiring a costly and power-hungry Gigasample Analog-to-Digital Converter. The digital core is based on a novel System-on-Chip solution (Xilinx Zynq SoC) providing into the same dice both Field-Programmable Gate Array logic blocks and processing cores. Receiver side, after protection stages, low-noise amplification and anti-alias filtering, the baseband waveforms are sampled and uploaded to a mainstream computer for data processing, visualization and storing.

Hardware-level waveform aggregation strategies aiming at improving the receiver sensitivity have been applied. Specifically, the polarity of the emitted waveform is alternately switched per each consecutive scan. Since the receiver electronics distortion floor is (at first approximation) independent from the waveform polarity (unlike targets and clutter returns) most of the floor will be notably lowered by digital sign compensation and summation of the scan pairs (a technique known as antipodal modulation, Fig. 2).



A few pairs of polarity compensated scans are then averaged. This short-term aggregation provides a first improvement over thermal noise and favors the effectiveness of the following stages. Noise shaping is performed on the oversampled waveform via low-pass filtering. A decimation stage performs then data reduction according to the waveform Nyquist frequency without loss of information. Resulting samples are finally averaged to generate the represented echoes for any given azimuth or to serve as input for a Doppler processor.

In August 2016 an experimental campaign took place in Kasbach to detect cargo vessels on duty along the Rhein River. Since a very limited transmit power of about two Watts was available, a short-range mode has been selected to generate radar maps up to about 500 meters. Both noise filtering and antipodal modulation proved to be essential processing steps to improve data quality. A final processor output superimposed to the location map is shown (Fig. 3). Targets and environmental features can be clearly identified. Clutter returns (vegetation and road echoes) have not been masked and are correctly geo-located, including echoes from stationed train wagons to the West.

Based on this successful measurement campaign, the suitability of said solid-state radar demonstrator for maritime navigation has been verified. An engineered solution based on the use of a trailer has proved sufficient to handle the safety and logistic aspects implied in working at S-band. A concept of scan framing has been investigated to implement techniques (like the antipodal modulation) able to notably improve the sensitivity floor. Novel approaches to signal and data processing have been showcased, including a real-time SoC digital engine as the foundation of a hardware-defined radar. Further developments are planned for the near future to improve radar performance and information processing capability.

- 1 *Transportable S-band radar demonstrator with gear-box and electro generator.*
- 2 *Receiver sensitivity before (a) and after (b) antipodal modulation.*
- 3 *Experiment location with superimposed processor results.*



Dr.
Stefano Turso
Phone +49 228 9435-136
stefano.turso@
fhr.fraunhofer.de



ANTENNA DEVELOPMENT FOR AN INNOVATIVE SEA RESCUE SYSTEM

Conventional navigation radar systems are normally not capable of detecting small objects on a rough sea surface. A modular expansion of existing radar systems and the utilization of cost-effective transponders should remedy this situation.

With increasing swell, it is very difficult or even impossible to detect small drifting objects on the sea surface, e.g. water sports enthusiasts, life rafts or castaways, using conventional maritime radar systems. The radar reflections of these objects are weaker or only slightly stronger than the reflections from the uneven water surface (sea clutter). Research into an innovative sea rescue system, which uses radar to detect people and rescue devices in the water, is currently being conducted within the framework of the publicly-funded joint project SEERAD (Sea rescue system based on low-interference radar).

Here, activities focus on the development of compact and cost-effective transponders that return a frequency-doubled radar signal that is received and evaluated by a harmonic – and also yet to be developed – radar system. This signal is not superimposed by typical interference caused by reflections on the waves with the result that all objects with transponders can be visualized.

The possibility of integrating the harmonic radar system with existing S-band navigation systems of the industrial partner is an important aspect of the project. The conventional navigation radar and the harmonic radar will share a common antenna and, for this reason, the transmit frequency range

of both systems must correspond within the S-band. The harmonic radar will receive the frequency-doubled scattering signals of the transponder at the doubled frequency in C-band, while the conventional radar continues to receive the linear reflection signals in the S-band. Due to the utilization of a common radar antenna, both systems have to use the same transmit polarization. Navigation radar systems typically use horizontal polarization. This, however, is not very suitable for the detection of objects that only slightly protrude from the water surface. For this reason, vertical polarization was selected as the receive polarization of the sea rescue radar.

As shown in the block diagram in Fig. 2, Fraunhofer FHR will focus on the investigation of innovative antenna structures for the transponder and the expanded navigation radar. Work on the transponder antenna, which is now largely completed, led to the development of a transponder with dimensions similar to those of a credit card. The integrability of the transponder in conventional life jackets was successfully tested in simulations and experiments conducted in dry and wet environments. As shown in Fig. 3, detectability is investigated from all spatial directions, including possible shading effects.

Maritime navigation systems usually use mechanically rotating fan beam antennas based on slotted rectangular waveguides. In the S-band, these antennas have a length of approximately four meters and have to contend with the environmental conditions at high sea. Fraunhofer FHR faces the special challenge of developing a compact antenna which meets the same high frequency and mechanical requirements as a conventional maritime radar antenna but can also receive with

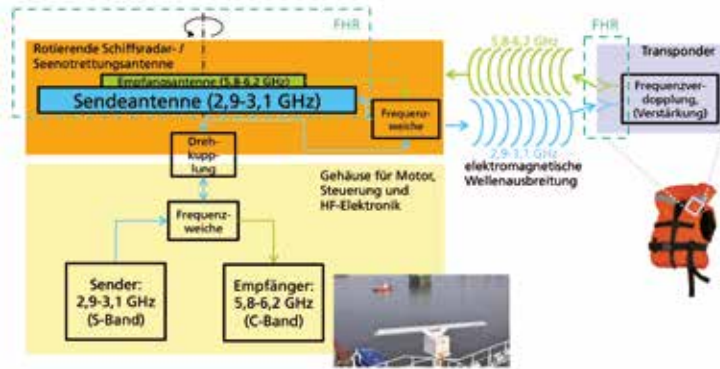

2



3

a different polarization at the doubled transmit frequency. A shorter demonstrator antenna has already been successfully constructed. The suitability of the selected approach was verified by measurements carried out in one of FHR's antenna measurement chambers and operational tests using an initial demonstrator of the harmonic radar hardware.

The next step involves the construction of a combined navigation and sea rescue antenna in full length so that the narrow beamwidth of the antenna in the horizontal plane, as required in the international shipping regulations, can be achieved. After completion and characterization, the antenna will be made available to the industrial partner for extensive measurement campaigns on the Baltic Sea.

The project is funded within the context of the BMBF initiative »Innovative Rescue and Safety Systems« as part of the »Research for Civil Security« program of the Federal Government. The project is led by the University of Applied Sciences in Aachen. The industrial partner is Raytheon Anschütz GmbH. The professional association Seenot-Rettungsmittel e.V. is an associated partner.

1 *Vision of a future sea rescue scenario: the transponder in the life vest allows detection with a harmonic radar.*

2 *Block diagram of the components of the sea rescue system. The responsibilities of Fraunhofer FHR are highlighted.*

3 *Experimental test of the transmit and receive characteristics of the transponder antennas.*

SPONSORED BY THE



Federal Ministry of Education and Research



Dr.-Ing.

Thomas Bertuch

Phone +49 228 9435-561

thomas.bertuch@

fhr.fraunhofer.de

1



UWB RADAR FOR THE DETECTION OF FUNGAL INFESTATION IN VINES

Fraunhofer FHR aims to improve the early detection of stem diseases in vines with a new UWB radar sensor. The sensor, along with other sensors that are currently available, will be integrated on the mobile multisensor platform of Televitis, an R&D group at the University of La Rioja and the Institute of Grapevine and Wine Sciences (ICVV) in Spain. Televitis fosters the research of new technologies for applications in precision viticulture and develops robot platforms for the regular monitoring of wine-growing regions.

In the last 30 years, stem disorders have developed to become one of the most destructive vine diseases and they now represent a growing threat in wine-growing regions around the world. Some studies suggest that the annual economic damage resulting from the replacement of dead vines amounts to approximately 1.5 billion euro.

Stem diseases are threatening the economic existence of many winegrowers. Their pathogens attack the vital organs of the plants and sooner or later provoke their death. The diseases are caused by fungi, the life cycle and epidemiology of which are all very similar. The diseases are not evident at first and their symptoms develop very slowly over several years with the result that they are very difficult to detect. The fungal spores normally access the plant via wounds that occur during the pruning process. The pathogens can also penetrate the plant via other mechanically inflicted wounds or via damage caused by frost. As they grow, they gradually decompose the wood and cause the plant to die slowly. The fruit bodies in the dead

wood and their spores are released by water, scattered by the wind and can now infect new wounds. The symptoms normally take the form of sectional or central necrosis in the wood which is recognizable by distinctive brown zones and signs of rotting. The leaves show discoloration and begin to wither, sometimes very quickly. This acute disease can not be treated. Hence, the infected plants have to be removed and burned to hopefully prevent the disease from spreading.

Early diagnosis with radar

External radar sensors can acquire information about the plant's interior. They can therefore detect the disease at an early stage and make a distinction between healthy and infected plants in the vineyard. In an earlier project, Fraunhofer FHR developed a radar sensor that is capable of monitoring crops, including an estimation of the water content and biomass of the plants. The scientists adapted this sensor for the detection of diseases in vine stems and conducted initial tests in a preliminary study. To this end, the University of La Rioja provided the scientists with samples of freshly cut vines in different stages of the stem disease.

The project aims to provide a mobile platform for the regular monitoring of wine-growing regions. This platform should be capable of evaluating information from optical, multispectral, hyperspectral and NDVI sensors.

So as to be in a position to adjust the geometry of the data recording of the mobile TELEVITIS platform also within the framework of initial laboratory tests, the FHR engineers used a robot arm which can be moved along six axes. This facilitated

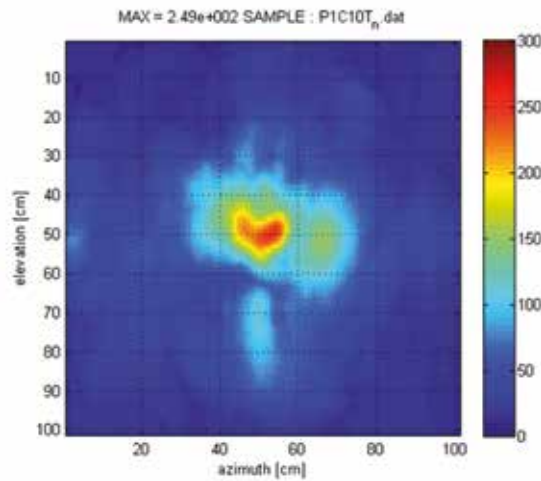
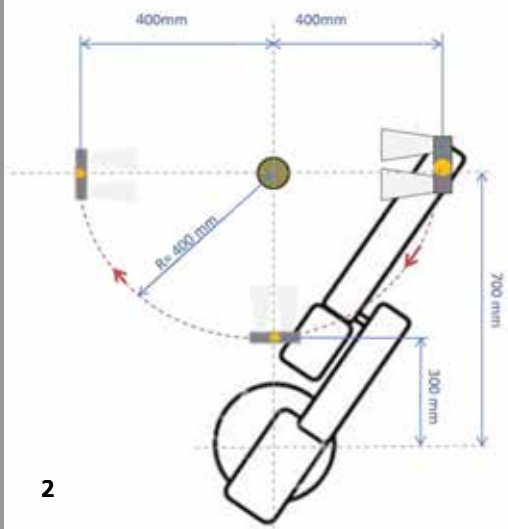

the testing of stripmap and spotlight recording modes in one- and two-dimensional scanning rasters. With the flexible robot arm, it was also possible to exploit polarization diversity and test other properties that are based on polarimetry.

On completion of the promising laboratory tests, the scientists used their radar sensor to carry out the first tests on living plants in several vineyards in Logroño, Spain in November 2017.

3D-analyses and computer simulation optimize sensor performance

Fraunhofer FHR is following different research approaches to improve the UWB radar sensor so that stem diseases in vines can be detected at an early stage and contained so that they can not spread across the vineyard. These include denser recording grids based on circular SAR approximation values at different heights as well as imaging techniques using inverse modeling. The three-dimensional angle of sight created in this manner should be able to quantitatively and spatially reconstruct the constitutive parameters inside the stems. Using the photogrammetric reconstruction from the optical camera on the platform, it will also be possible to create 3D models of each vine. These, in turn, can be included in the SAR processing so as to further improve the inverse modeling.

In addition, the scientists want to create computer simulations of the course of the disease inside the vine stem. To this end, a large number of samples in different stages of the disease will have to be analyzed. This will lead to a better understanding of the course of the disease and, with exact simulations, the sensitivity of the radar sensor can also be increased to ensure that this major viticultural problem can be detected as early as possible.

1 *Vine samples from a vineyard in different stages of necrosis.*

2 *Schematic representation of data acquisition with the robot arm along with an example of the data obtained in this manner after focusing.*



Dr.-Ing.
Fernando Rial Villar
Phone +49 228 9435-770
fernando.rial@
fhr.fraunhofer.de

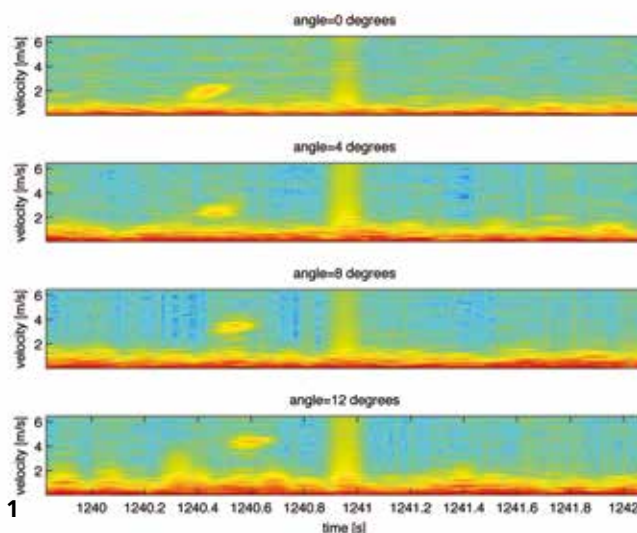

COLORS: ANOTHER STEP TOWARDS BIRD PROTECTION IN WIND FARMS

In times of climate change, growing importance is being attached to renewable energies and, in particular, wind energy. The suitability of a radar sensor as a bridge-builder between the profitable utilization of wind power and statutory bird protection regulations is currently being examined within the framework of the project COLORS.

Background and goals of the study

The study aimed to detect birds in the direct vicinity of wind turbines and analyze their movement in order to carry out a subsequent risk analysis. In cases where birds are in imminent danger, this radar could send a corresponding signal to the control network, whereby operation of the respective turbines can be halted.

The work is carried out in the light of court rulings similar to the decision of the Administrative Court in Minden [VG Minden, 08.08.2016 – 1 L 1155/16]. These provide for subsequent operational restrictions, i.e. the temporary deactivation of individual wind turbines when there is a significant lethal risk to birds of protected species. This case in Minden related to a black stork population which settled in the direct vicinity of wind turbines. The court stated that there was presently »no milder means that could equally guarantee the Black Stork's chance of survival.« The project COLORS takes the first step towards providing these milder means.

Preliminary work

The system parameters necessary to implement a corresponding sensor were determined on the basis of a feasibility study that was carried out in 2014. The results of the study show that a radar operating in the Ku-band with 20 W transmit power is suitable to meet the specified requirements. Aspects relating to the subsequent approval of the system by the Federal Network Agency were also considered. The feasibility study revealed that the antenna must have a high update rate to guarantee wide-area monitoring of the wind farm. Hence, a detailed examination of an electronically steerable antenna concept was carried out in the course of the COLORS study.

Experimental tests

The functionality of the newly developed demonstrator system was tested within the framework of experimental measurements. The first measurements were taken inside a wind farm to investigate the effects of the wind turbines. On this occasion, there was no suitable bird in the wind farm and, for this reason, a hexacopter was used as a calibrated measurement object.

Similar to a bird, the hexacopter exhibited a varying flight path over time. The measurements, which covered a spread of 40°, included wind turbines and open fields. In spite of the reflections caused by the rotors of the wind turbines in the wind farm, it was possible to detect the hexacopter and measure its movement path. Figure 1 illustrates the capacities

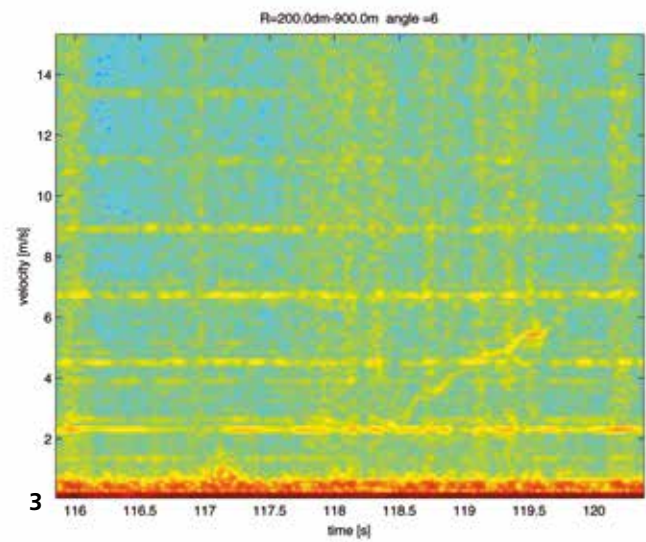
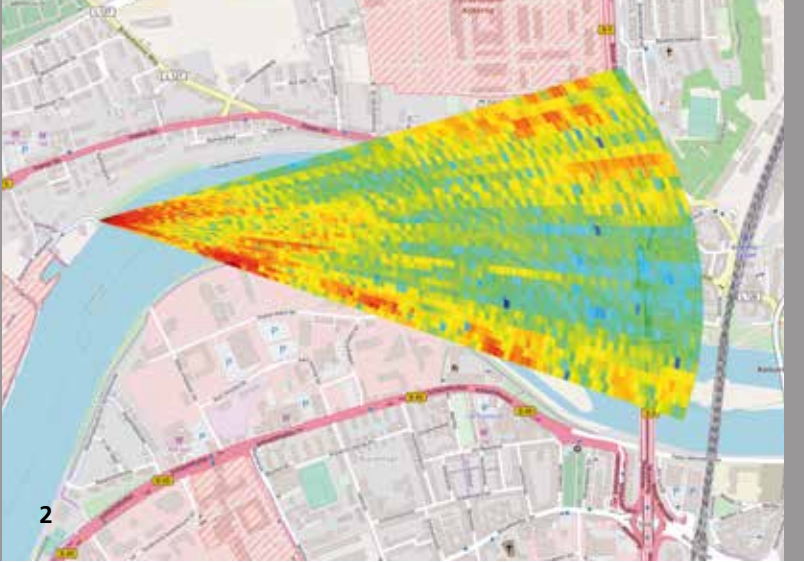

of the radar demonstrator. It shows a diagonal flight of the hexacopter in the wind farm. The observed movement is characterized by radial acceleration with simultaneous »migration« through the antenna beams. The radar therefore has the ability to measure lateral as well as radial movements. The vertical line in all of the illustrations in Figure 3 shows temporary interference caused by a wind turbine rotor in the direct vicinity of the hexacopter. Due to the periodic movement of the rotors, this interference can be suitably predicted.

Further measurements taken at a dam on the Mosel in Coblenz (comp. Fig.2) featured the measurement of a cormorant which, in terms of its body size, is similar to the stork cited in the court ruling in Minden [VG Minden, 08.08.2016 – 1 L 1155/16]. During the measurement, the bird started its flight at a distance of approximately 500 meters. The increasing speed can be clearly seen in Fig. 4, the Doppler spectrogram of a single spatial direction.

Outlook

Long-term tests, in which the influence of the wind turbines can be determined in different weather conditions, are necessary for the further development of the demonstrator system. Given that the speed and orientation of the wind turbines are determined by environmental influences, it was not possible to investigate all possible scenarios in the first test measurements. Tests, in which the waveform is optimized by means of an additional micro-Doppler analysis of the wing beats, are also planned.

- 1 *Detection of a hexacopter flying in a transverse direction in the wind farm over several adjoining antenna beams.*
- 2 *Experiments on the Mosel in Coblenz.*
- 3 *Detection of a cormorant in the presence of dynamic clutter caused by the flowage of the river Mosel.*

Dipl.-Ing.
 Christoph Wasserzier
 Phone +49 228 9435-228
 christoph.wasserzier@
 fhr.fraunhofer.de

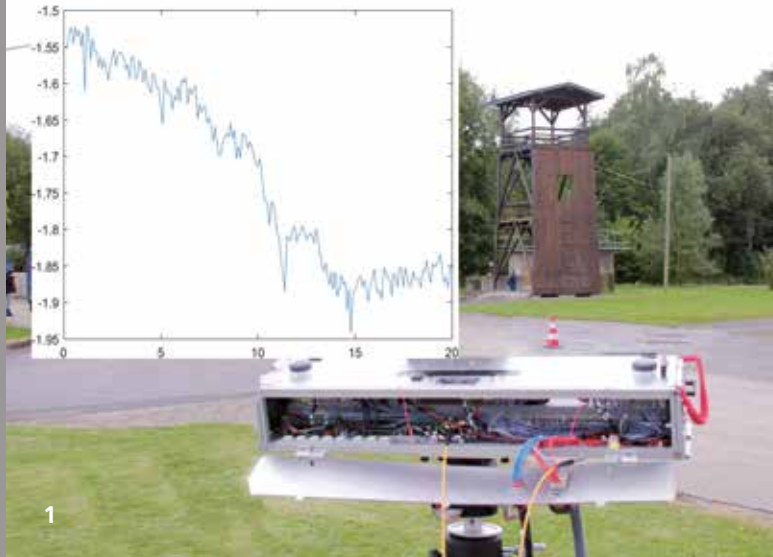

RAWIS PROTECTS RESCUERS DURING EMERGENCIES

Every minute counts when buried and seriously injured people have to be found and rescued in an emergency situation. Thanks to its continuous monitoring ability, RAWIS supports the rescue workers in these highly dangerous situations by providing timely and individual warnings prior to a potential debris collapse.

Emergency scenario

Fast action is necessary in the case of an emergency as human lives are often in danger. For this reason, the rescue workers could quickly find themselves in very dangerous situations arising from the complex and continuously changing conditions at the scene of the emergency. Damaged walls, sagging roofs and debris of all kinds could topple or slide and, in a worse case scenario, injure or even lead to the death of the rescuers. Moreover, the risk situation changes permanently during the search and debris removal operations as debris that is assumed to be stable can quickly become unstable and collapse.

RAWIS project

To protect the rescue workers engaged in disaster relief, an experimental system was researched and constructed within the framework of the RAWIS project (Radar Warning and Information System for Applications in Disaster Control) which was funded by the Federal Ministry of Education and Research. This system continuously monitors the scene of the emergency and assists the rescue workers in the assessment

of the danger level through the provision of high-precision measurements and individual, personalized warnings.

RAWIS comprises four central components: the main 3D MIMO radar for three-dimensional monitoring of the entire scene, small battery-operated support radars for the precise monitoring of shaded debris, a radiolocation system which safely pinpoints the location of each individual member of the rescue team and can issue individual warnings and, last but not least, a control station where all information is gathered and graphically displayed.

Radar systems

The main imaging radar is designed for a typical range starting at a couple of meters and extending up to several hundred meters. Test measurements taken at the training grounds of the THW in Handorf safely detected movements with a precision of 30 μm . The entire deployment area was monitored with a measurement rate of up to 1 kHz. Antennas in SIW technology, which were specially developed at Fraunhofer FHR, illuminate the entire deployment area and record all movements. Sophisticated signal processing methods guarantee that all irrelevant movements, e.g. caused by rescue vehicles, the rescue workers, search dogs and trees, are identified and filtered out. The MIMO principle, which uses a greatly reduced 2D MIMO array for three-dimensional monitoring of the deployment area, was applied to reduce weight, dimensions and costs. The MIMO array comprises individual transmit and receive modules so that it can be expanded as required to increase, for example, the spatial resolution for



specific applications. The implemented compressive sensing methods guarantee the usability of the MIMO system even when individual antennas or modules fail during operations in harsh conditions.

The support radars monitor debris movements in shaded areas that cannot be accessed by the main radar. The camera-sized sensors are brought to the scene by the helpers and directed towards potentially dangerous debris piles. In the event that movements or noticeable vibrations are detected within the detection range (approx. 30m), corresponding measured values are forwarded to the control station where the building surveyor on duty can assess the danger and, if necessary, evacuate the area. When the rescue workers have completed the necessary work in the deployment area, the sensors can then be moved to other shaded areas or to a location inside a building. One special feature of the support radars is high-precision range measurement through the utilization of battery-operated FMCW radar devices that enable reproducibility in the micrometer range. The state-of-the-art hardware combined with signal processing that is implemented in a sensor clearly demonstrates the potential of a miniaturized radar-based sensor system that can be used as a handheld device for high-precision metrology applications.

One special feature of radar sensors is that they can penetrate rain, fog, snow, dust and smoke. Added to this, they are suitable for day and night operations.

Joint project

The RAWIS consortium comprises eight partners: Fraunhofer FHR, the Federal Agency for Technical Relief (THW), the University of Siegen, the Ruhr University Bochum and indurad are funded partners. The Federal City of Bonn and the companies Elettronica and unival are associated partners.

1 *Tilting building represented by a tower being pulled with a winch. The curve shows the movement in millimeters over a 20-second period for an individual radar image point.*

2 *Typical application scenario for RAWIS.*

3 *The compact support radar records – with micrometer precision – changes in the position of debris that is located outside of the main radar's detection range.*

SPONSORED BY THE



**Federal Ministry
of Education
and Research**



*Dr. rer. nat
Jens Klare
Phone +49 228 9435-311
jens.klare@
fhr.fraunhofer.de*



DRONE DETECTION WITH MICRO-DOPPLER ANALYSIS

Drone detection now plays an instrumental role in security concepts. The use of micro-Doppler analysis to determine additional characteristics of the flying objects, such as the object class, size and weight, facilitates an estimation of the level of risk caused by the drone.

Compact radar devices can be used to monitor local airspace so as to protect objects or events from threats posed by drones. The strength of the signal received allows conclusions to be drawn with regard to the approximate size of a detected object, but further analysis is, however, not possible. Further information relating, for example, to the type of the detected object (bird, fixed-wing airplane, helicopter, quadcopter, octocopter), the size of the object and the possible load capacity is desirable. A special radar mode and micro-Doppler analysis is necessary to draw conclusions relating to the number of propellers and their rotational speed.

Construction of a micro-Doppler demonstrator

The demonstrator DroMiAn (Drone detection with micro-Doppler analysis), which, in addition to the normal radar hardware for object detection, also has an additional channel for micro-Doppler measurement, was constructed to research the micro-Doppler signatures. This demonstrator operates at a fixed frequency of 94 GHz. In a first step, the demonstrator was used to measure rotating objects in the measurement chamber. Free-field measurements with a flying drone were carried out at a later stage.

Measurements in the measurement chamber

Rotating bodies of the same length, including a tube and different types of propellers, were used in the first test measurements with the demonstrator. These were measured at varying rotational speeds and inclinations. The frequency and speed of the rotating objects can be clearly determined from the recorded data. These two values can then be used to calculate the size of the object.

Free-field measurement

The first free-field test measurements involved the measurement of a quadcopter in different flight scenarios, i.e. hanging motionless in the air, flying slowly from left to right, flying slowly towards, away from and over the radar device. In addition, comparative data of individual pedestrians and groups of pedestrians was recorded to create false targets for the evaluation algorithms.

Compared to the measurements in the measurement chamber, the evaluation of the real free-field measurements proved to be much more difficult as, instead of measuring the signature of a single propeller, it was now necessary to measure a sum signal made up of the reflections from several propellers and the body of the drone.

Evaluation

The measurement data was evaluated in several steps. The first step involved creating a spectrogram from the complex ra-

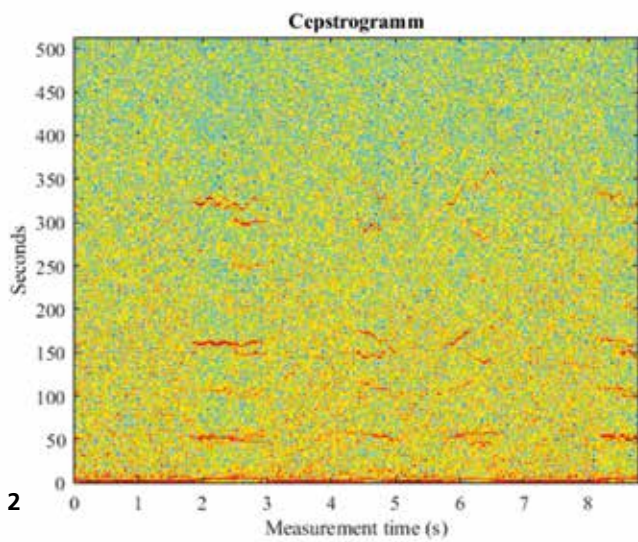

2

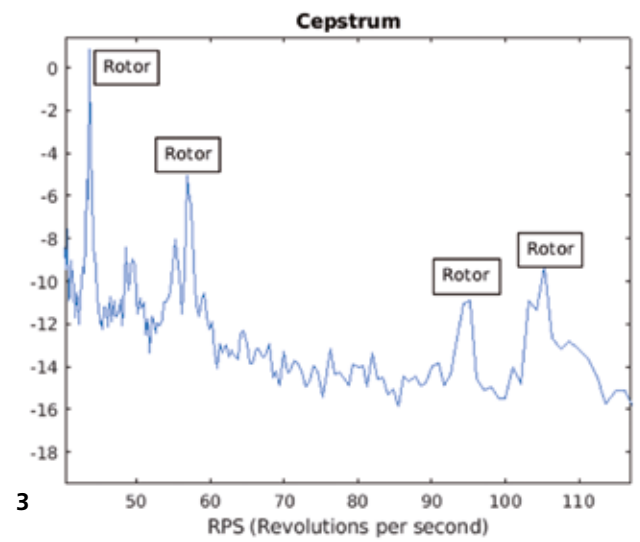

3

dar data. This is made up of a series of Fourier transformations which are specially adapted for the respective conditions so as to achieve the best possible results. Before processing continues, this spectrogram is optimized through the suppression of fixed targets and the removal of noise components. In a further processing step, features are extracted by means of singular value decomposition. This technique provides good results, particularly in the case of the individual pedestrians or the pedestrian groups. In the case of the measured drone, the features were extracted from a cepstrogram. This is a technique originally used for frequency analysis in the area of sound technology. When used in conjunction with radar data, it provides good results when determining the rotational speed of the rotors. The individual rotor speeds can subsequently be read from the cepstrogram or the cepstrum, a cross-section of the cepstrogram.

Target classification

Target objects are classified by comparing the measured data with the database of known objects. As a sufficiently large database with measured objects was not available for the tested frequency range, synthetically generated data from drones, birds and other objects with complex dynamics was used. In the first classification tests, a correct classification rate of 86% was achieved for the measured drones and the classifications for individual pedestrians and pedestrian groups were 100% correct.

Outlook

In the meantime, new data sets for drones of different types have been recorded with the further developed radar demonstrator. This data will be analyzed with new signal processing and target classification approaches.

- 1 *Free-field measurements of drones with the micro-Doppler demonstrator Dro-MiAn.*
- 2 *Cepstrogram of the measured drones.*
- 3 *Cepstrum of the four rotor blades of a drone flight. Due to the flight movement of the drone, two of the blades are rotating faster.*



Dr. rer. nat.
María González-Huici
Phone +49 228 9435-708
maria.gonzalez@
fhr.fraunhofer.de

Dipl.-Ing.
Thorsten Brehm
Phone +49 228 9435-354
thorsten.brehm@
fhr.fraunhofer.de



WIDTH DETERMINATION OF STEEL STRIPS IN THE ROLLING PROCESS – RADAR SYSTEMS FOR INDUSTRIAL APPLICATIONS

Conventional measurement systems are frequently not able to cope with the harsh environmental conditions in hot rolling mills. For this reason, Fraunhofer FHR and IMS Messsysteme GmbH have, for the first time, developed a precise width measurement system based on radar technology. One great advantage of this system is the fact that it can be used even in the most adverse conditions.

Harsh environmental conditions and high demands

Quality and efficiency in the production of rolled products are very closely linked to the development and usability of measurement techniques for tracking and regulating the rolling process. Improvements to existing measurement techniques increase productivity and reduce production costs. The width of the steel strip is a fundamental parameter in the rolling process. Due to the presence of dirt or steam, conventional measurement systems can not be used or can only be used with great difficulty to take a width measurement at the roughing stand, one of the essential width regulation steps in the rolling process. Parallel to this, the requirements placed on the sensors, even under these conditions, are very high. Apart from precise measurement, requirements include high reliability in 24/7 operation, temperature stability over a range of -10°C to 55°C , robustness against vibrations as well as fast and easy integration into existing systems.

In the past, regulation was carried out on the basis of theoretical models and empirical values. However, errors that occur at this point cannot be corrected in the course of rolling process as the width can no longer be influenced in later processing stages. To guarantee that the target width is achieved over the entire length of the strip, the strip is rolled wider than required and the surplus width is removed at the end of the rolling process. Over the course of a year, this excess width produces several thousand tons of steel scrap which has to be melted down again. This not only requires additional resources such as energy, material, personnel and machine hours but also results in the production of several tons of CO_2 per year. Moreover, each millimeter of excess width reduces the length of the strip and hence, the overall output.

Fraunhofer FHR, in cooperation with IMS Messsysteme GmbH, has developed a radar-based width measurement system to close this gap in process control. Two frequency modulated continuous wave radars independently measure the distance to the steel strip that is passing the radar beam. For this purpose, they are installed opposite each other on either side of the rolling path. Calibration then takes place to correlate the two measurements so that the width and the center position of the strip can be determined on the basis of the range measurements.

From the laboratory to the steel mill

The radar systems were tested in the testing facilities of IMS Messsysteme GmbH. In line with the planned installation sce-

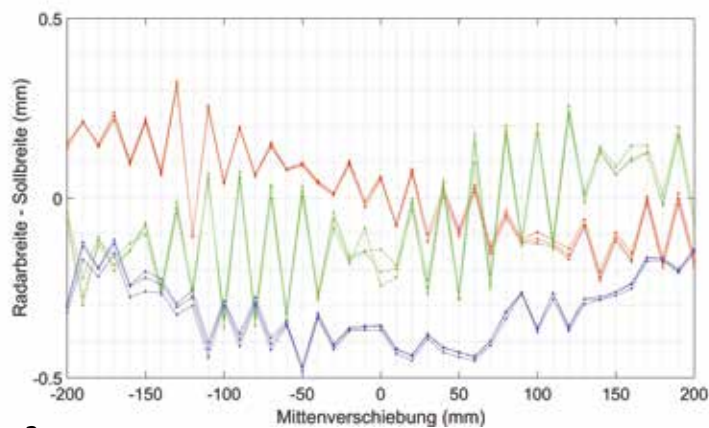

2

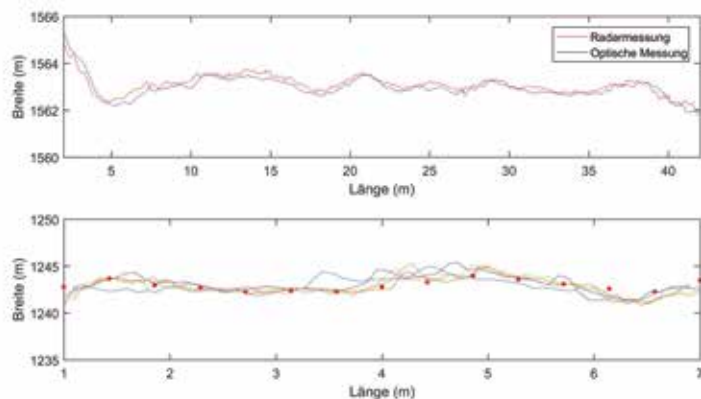

3

nario at the rolling path, two radar systems were installed opposite each other at a distance of 5 m. A positioning unit, which moves various test and calibration bodies along the axis between the two radar units, is located between the two systems. The encoder of the positioning unit, which is certified for $\pm 60 \mu\text{m}$, is used to control the individual distance measurements. The certified test bodies with typical widths that occur at the roughing stand serve to monitor the measurement accuracy of the width measurement system as a whole. The required measurement accuracy at the roughing stand of $\pm 1 \text{ mm}$ was easily achieved with a deviation below $\pm 0.5 \text{ mm}$ for all widths. Fig. 2 shows the difference between the measured and the certified width value.

The radar-based width measurement system was installed and tested at the roughing stand in the hot strip mill of Salzgitter Flachstahl GmbH. Due to the small size of the sensor system and the independence of the individual sensors, the size of the installation can be adapted to the respective measuring sites. Fig. 1 shows the installed width measurement system at the roughing stand at Salzgitter Flachstahl GmbH. Steel strip with widths of between 800 mm and 2050 mm and thicknesses of between 50 mm and 250 mm are rolled here. An optical width measurement system of IMS Messsysteme GmbH is located behind the roughing stand at the entrance of the production line. Fig 3 shows an example of the width profile of a steel strip which was measured by the radar-based width measurement system and the optical measurement system. The width profiles of both systems show a high level of agreement. The radar width measurement is not influenced by the very harsh conditions at the roughing stand.

To further test measurement accuracy, a piece of strip with a length of 7 meters was cut out of the input strip, placed on the rolling path and once again measured and tested by the radar measurement system. The results are shown in Fig. 3. There was a high level of agreement between the radar measurement and the manual measurement. The radar measurement also displayed high repeatability.

For the first time, the obstacles to precise width measurement in hot strip mills were overcome with radar technology. At the beginning of 2017, a fully industrialized version of the radar-based width measurement system was installed and commissioned in Salzgitter. Since then, the radar width measurement system has been measuring the width of steel strips reliably, precisely and trouble-free in 24/7 operation. In addition to the advantages described above, the system parameters of the measurement system can be adapted individually with the result that radar measurement is also very attractive for other application areas.

1 *Aufbau der Radarbreitenmessung am Vorgerüst der Salzgitter Flachstahl GmbH.*

2 *Laborergebnisse zur Messgenauigkeit. Dargestellt ist die Differenz zwischen der mittels Radarsystem gemessenen und der zertifizierten Breite der drei Prüfkörper.*

3 *Oben: Beispiel eines Breitenprofils gemessen mit der Radarbreitenmessung und der optischen Messung am Einlauf der Fertigstraße. Unten: Vergleich zwischen Radarmessung (Linien) und manueller Schieblehrenmessung (Punkte).*



Dipl.-Ing.
Christian Krebs
Phone +49 228 9435-775
christian.krebs@
fhr.fraunhofer.de



3D RADAR IMAGES FOR TRANSMISSIVE INSPECTION OF OBJECTS

Based on its integrated radar sensors, Fraunhofer FHR has developed techniques and algorithms for three-dimensional imaging with a millimeter wave scanner. The quality of the images created with this technology is very impressive.

Fraunhofer FHR develops highly integrated radar modules on a silicon-germanium (SiGe) basis and is therefore in a position to provide cost-effective and compact systems for numerous industrial and security applications. This, combined with the institute's effective imaging algorithms, paves the way for the creation of high-performance imaging systems. Parallel to the development of a flexible robotics module, Fraunhofer FHR also created a complete laboratory measuring system. In addition to checking luggage for illegal contents, the system is capable of carrying out material and fault analyses for scientific and industrial applications.

High resolution due to high frequency and large scanning area

Similar to camera systems, the resolution of radar images greatly depends on the size of the lens. In the case of radar images, this is achieved through the interconnection of numerous antenna elements over a surface. The millimeter wave technology of Fraunhofer FHR now allows images of up to 300 GHz, with the result that image resolutions below one millimeter are possible. This value can also be considerably surpassed when using thicker materials. An extremely high

number of measurements is, however, required and this proves to be a challenge in the presence of large surfaces: scanning a surface measuring one square meter with a distance of one millimeter would require one million antenna positions. This is next to impossible when using conventional panels. The serial measurement of the individual positions is a feasible alternative in cases where the measurement object can be scanned for a number of minutes.

Scan produces images with little technological effort

The researchers at Fraunhofer FHR use a synthetic aperture radar (SAR). Instead of using multiple antennas at the same time, the antennas move over the aperture. All of the individual measurements are subsequently grouped to obtain a complete picture.

The highly integrated radar modules at 80 GHz developed in cooperation with the Ruhr University Bochum are sensors that offer a high level of performance. The installed scanning system can contend with any required scanning area with an edge of up to one meter in length. Moreover, the utilization of network analyzers or integrated sensors also allows the creation of images at 30, 60, 120 or 240 GHz.

Luggage scan for detection of hidden objects

Tests in which the 80 GHz scanning technology was used to screen luggage proved to be successful. The complete 3D reconstruction of the interior provides information relating not only to the shape of the contents but also to their position in

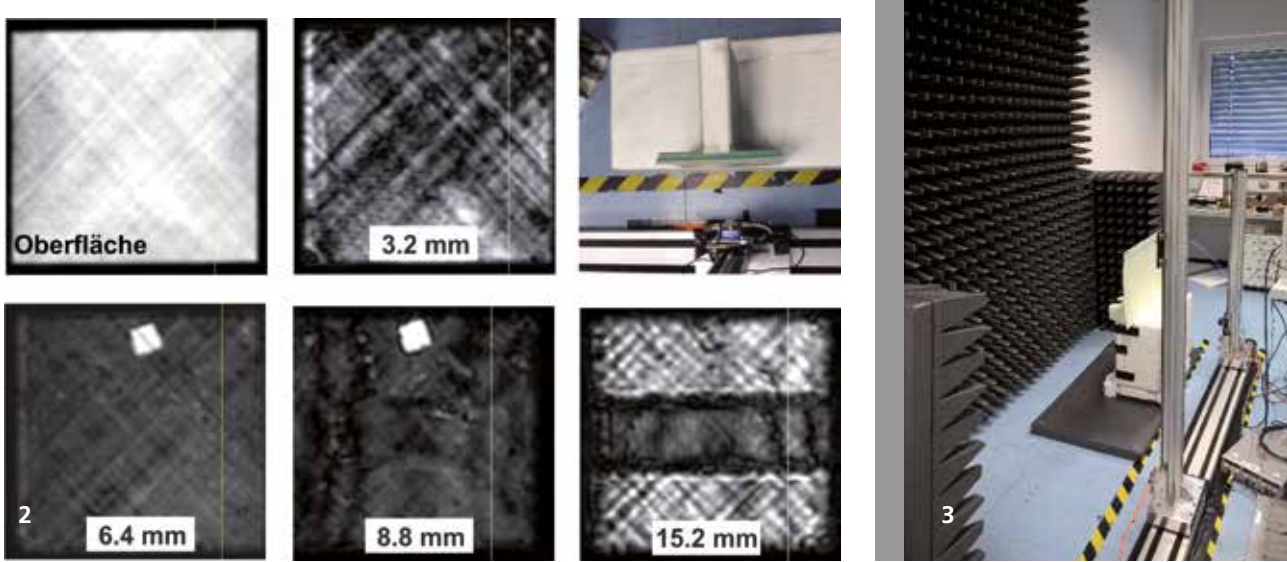

space. This is not always possible when using conventional X-ray scanners. Furthermore, the contents can be screened layer by layer or visualized in 3D.

Figure 1 shows the result for a suitcase that measures 70 cm in width. In the summation, the suitcase is clearly visible across all layers. In particular, the strong reflection of the outer shell is easily discernable. Decisive Of major interest is, however, the handgun inside the suitcase which can be seen with a high level of detail. This becomes even more clear when an isolated layer inside the case is viewed. The radar's depth resolution of up to 5 mm hides the reflections of the outer shell.

Material scan and fault detection in fibrous composite materials

Transmitted light imaging also plays an important role in the detection of production faults and signs of fatigue in industrial quality assurance. Within the framework of the DIARO project, which was funded by the state of Bremen, the researchers at Fraunhofer FHR used this scanning technology to detect faults and imperfections in wind turbine blades. The primary aim was to detect inclusions, undulations or cracks in the material in a non-destructive manner. Figure 2 illustrates the possibility of layer by layer inspection. At first, the image is dominated by the strong reflections of the surface. The fibrous structure of the fiberglass composites are well visible 3 mm inside the sample. A foreign object which was inserted for test purposes can be seen at a depth of 6 mm. The bonding material between two of the composite panels is visible further inside. This allows the contact-free measurement of the bonding material. The rear side of the two bonded panels can be seen at a depth of 15 mm in the form of strong reflections. A depth resolution of 2 mm is possible in the thick material thus paving the way for high-precision tests.

Expansion potential to cost-effective multi-channel systems

The main disadvantage of the scanning method is the comparatively long measurement time. The scanning procedure for measurement ranges with less than 25 cm expansion currently takes less than 7 minutes. The integration of several measurement channels in a module should significantly accelerate the measurement time. The newly developed system should also be capable of measuring larger surfaces in just a few minutes. Fraunhofer FHR and its cooperation partner aim to integrate this technology in production lines. This will pave the way for the utilization of this very effective imaging technique in numerous applications.

- 1 Screened suitcase visualized as a whole (all layers summed up) with a small firearm (single deep layer).
- 2 80 GHz screening of a wind turbine rotor blade adhesion with different penetration depths.
- 3 Radar near field scanner at Fraunhofer FHR for imaging measurements at 5 to 300 GHz.



Dr.-Ing.
Reinhold Herschel
Phone +49 228 9435-582
reinhold.herschel@
fhr.fraunhofer.de



IDENTIFICATION WITH MILLIMETER WAVE TAGS

Product piracy is a major problem, but embedding RFID tags in products is normally quite a difficult task. The Radar Tag project should, however, lead to the design a transponder system at 60 GHz which will allow the integration of the complete tag including the antenna on a tiny chip (1mm²).

Miniaturized RFID tag offers protection against product piracy

In a world of global trade, product piracy is extremely difficult to contain. According to VDMA estimates, the damage in Germany alone comes to 7.3 billion euro a year. Although diverse protection mechanisms exist, these are often too complex or difficult to embed in products. A lot of time and money is spent trying to trace simple tags with serial numbers or QR codes. Electronic RFID tags, on the other hand, offer cryptographically protected authentication. These, however, still operate on a near-field communication basis (NFC; 13.56 MHz) or in the UHF band (868 MHz) and therefore require large antennas that measure several centimeters. With a view to creating a much more compact RFID tag, a transponder system which operates in the 60 GHz band will be designed within the framework of the Radar Tag project so that the antenna can be fully integrated into a chip together with the digital component, the cryptography module and the power rectifier. The chip (e.g. 1 mm²) accommodates the complete tag and can easily be embedded in products. A reader at 60 GHz supplies wireless power to the tag at the time of read-out. For the purpose of

information transfer, data that can be read by the reader is modulated on this signal.

Optimal solution through cooperation

The aspired transponder system is a very challenging task, not only due to the complex millimeter wave technology, but also because of the energy-saving cryptography and the sophisticated communication technique. The Fraunhofer institutes IPMS, IMS, AISEC and FHR joined forces to tackle this challenge. IPMS has the expertise necessary to realize the RFID tag, AISEC is the expert for the realization of the cryptography, IMS will provide the back end of the transponder system and FHR, with its experience in millimeter wave technology, is responsible for the read-out unit.

The challenges of creating the 60-GHz reader

The realization of the reader front end involves a number of interesting challenges. An extremely compact design is necessary to create a compact reader module in the format of a smartphone. A high transmit power, which, to the greatest extent possible, exploits the regulatory limit of 20 dBm EIRP in the far field, has to be produced for the energy supply. Energy-efficient signal generation is, of course, also necessary to reduce the space needed for cooling and energy supply to a minimum. The requirements placed on the receiver are also very demanding as this continuously receives the strong crosstalks and reflections of the 60 GHz transmit signal and, in spite of this, must work in a manner that is sufficiently linear to cleanly decode the backscatter modulation of the tag. Due

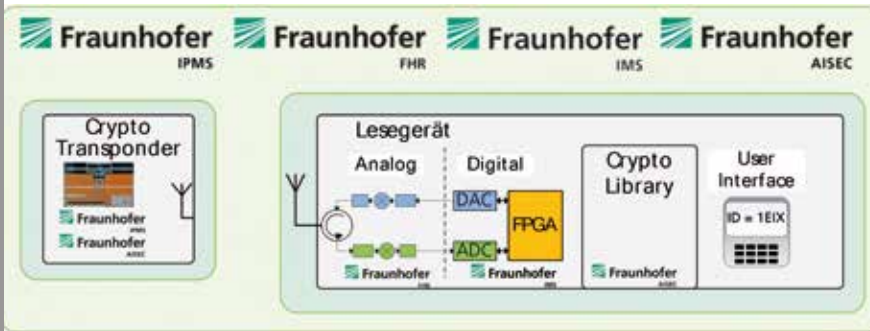

2

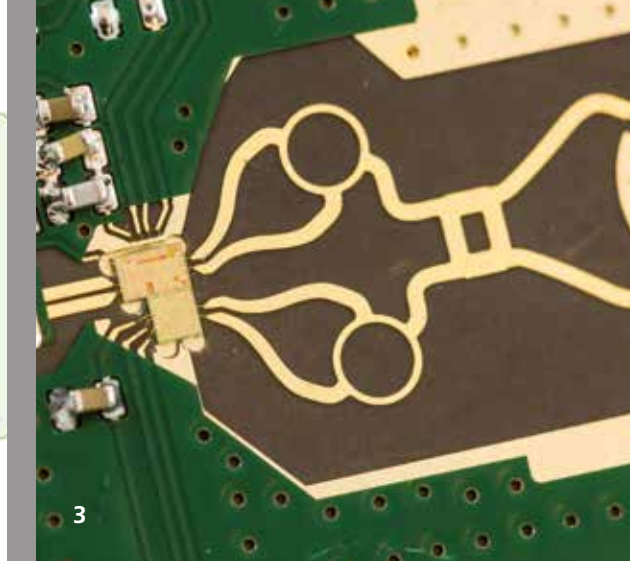

3

to this combination of demands on the high frequency technology and the aspired, low-cost scaling for the mass market, the front end is destined for integration on a silicon-germanium chip.

A further challenge is the achievement of robust wireless communication independent of the orientation of the reader and the tag. Due to its compactness, the antennas on the tag always have a linearly polarized design. In spite of this, the signal and energy transmission should always function regardless of the orientation of the reader. To achieve rotation independent control, the transmit and receive antennas on the reader have a circularly polarized design and they are both realized in a spatially concentrated antenna.

A first version of the reader, together with an internally developed transceiver chip, has already been realized within the framework of the project. The necessary transmit power has been verified in tests and, using an internally realized dummy tag, a backscatter modulation was successfully decoded at the receiver. Due to the results achieved and the challenges that still remain with regard to the integration of the entire system, the project team is looking to the final project year with optimism and is confident that the complete system will be demonstrated successfully in 2019.

- 1 *Vision of the Radar Tag project: the compact 60-GHz tags can be completely embedded in products.*
- 2 *Schematic representation of the transponder system with the respective institutes and their responsibilities.*
- 3 *First version of the reader board. The receiver chips and the couplers on the high frequency substrate, which form the transmit-receive switch and control the circular feeding of the antenna, can be clearly seen.*



Prof. Dr.-Ing.
Nils Pohl
Phone +49 234 32-26495
nils.pohl@
fhr.fraunhofer.de



RELIABLE QUALIFICATION OF AUTOMOTIVE RADARS WITH ATRIUM

ATRIUM is a radar target simulator for E-band. The system, which is currently being developed by Fraunhofer FHR, will be used to comprehensively inspect the functionality of automotive radar sensors of the next generation. In contrast to conventional radar target simulators, ATRIUM will be able to fully simulate critical traffic scenarios.

Due to various utilization possibilities (private and freight transport) and numerous advantages (enhanced driving comfort, greater economic benefits), autonomous driving is one of the most promising technologies of the future. Special attention must, however, be dedicated to the safety of autonomous driving to protect road users from unnecessary dangers and increase social acceptance for this technology. This also applies to the functional efficiency of currently available driver assistance systems which already perform important safety-relevant functions in automobiles. In particular, the reliability of automotive radar sensors must be guaranteed as these constitute an important component of such driver assistance systems and are also destined to play an important role in future automobile generations. This calls for a test environment which enables the extensive qualification of automotive radar sensors.

ATRIUM (Automobile Testumgebung für Radar In-the-loop Untersuchungen und Messungen) is a radar target simulator currently being implemented by Fraunhofer FHR for E-band. This will facilitate the realistic simulation of traffic scenarios through the generation of an electromagnetic wave field,

whereby the target simulator will be able to place virtual radar targets in any required position. Moreover, the movement of radar targets can be simulated through continuous position changes as well as through Doppler shift. In addition, the system will be capable of recreating complex target signatures, whereby radar targets from radar sensors will not only be perceived as points but rather as diverse objects comprising several components (e.g. rear, bumper, wheels). This functionality facilitates the simulation of traffic scenarios in which the reliable functioning of automotive radar sensors makes a decisive contribution to traffic safety.

The target simulator takes the form of a test stand which is positioned in front of a test vehicle equipped with radar sensors. In this way, the following applications can be covered:

1. The sensor manufacturer must prove to the automobile manufacturer that the radar sensor works trouble-free. Up to now, this proof is furnished through road tests. Thanks to the utilization of the ATRIUM radar target simulator, the number of test kilometers driven on public roads can be greatly reduced. This paves the way for fast and cost-effective verification of radar sensors.
2. When developing new or updated software functions and hardware components, tests should be carried out in a true-to-life environment. The radar target simulation is also capable of meeting this requirement.
3. If the automobile manufacturer would like to check whether the radar sensors provided by the sensor manufacturer

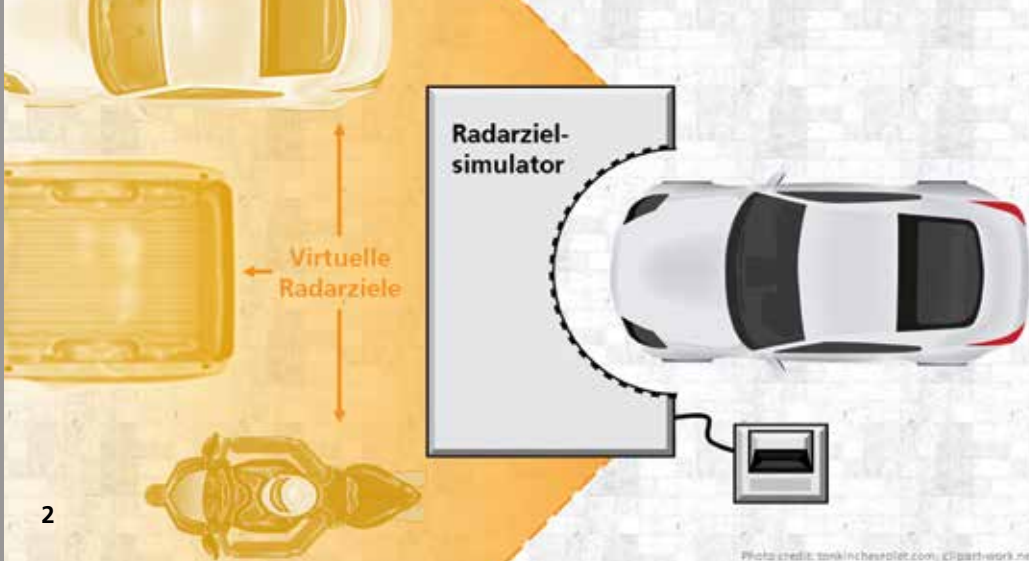

meet the required specifications, the automobile manufacturer also has to rely on proof that is provided through test runs. The radar target simulator can also be used for this purpose.

Digital boards equipped with FPGAs and transmit and receive units are used to allow the virtual positioning of radar targets along various spatial dimensions. The digital component allows the generation of Doppler and time-shifted as well as amplitude and phase-varied copies of the transmit signal. Through this modification, the signal can also be temporally delayed, whereby the distance of the radar targets can be changed. Moreover, the spatial arrangement of the transmit and receive antennas allows an angle-dependent representation of the more than 100 virtual radar targets.

Thanks to the new top-down approach, even the simulation of complex scenarios becomes easy: here, a high-level description of the traffic scenario based on the OpenScenario and OpenDrive standards is simulated using a point scatter model and the simulation result is divided into parameters that can be interpreted by the ATRIUM hardware. The user of the system no longer has to spend a lot of time positioning the individual radar targets.

In this way, ATRIUM will promote the qualification of radar-based driver assistance systems and make an important contribution to the safety of all road users today and in the future.

1 *Demonstrator to prove the functional principle of the hardware.*

2 *Artistic interpretation of the radar target simulator.*



Dr.-Ing.

Thomas Dallmann

Phone +49 241 80 22271

thomas.dallmann@

fhr.fraunhofer.de

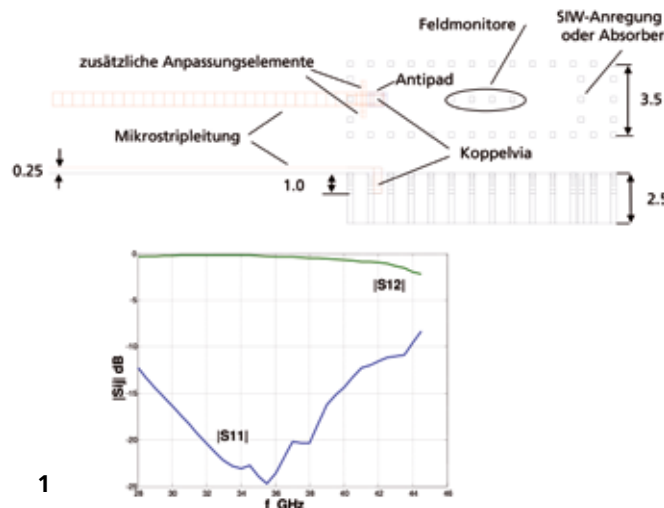

CHARACTERIZATION AND DESIGN OF SIW COMPONENTS AND ANTENNAS

An enhanced electrodynamic simulation system for components and antennas with substrate integrated waveguides continuously supports their entire development chain from design to characterization. The advantages of SIW components for high frequency applications in the millimeter-wave range can be fully exploited with a high degree of accuracy during the seamless monitoring of the entire solution process.

Efficient modeling thanks to innovative simulation method

SIW components can be used, together with microstrip and coplanar lines, to realize printed circuit boards (PCBs) in a cost-effective manner, they are characterized by low loss similar to rectangular waveguides, and pave the way for innovative circuit and antenna structures. In principle, they are made up of a wide microstrip line, the edges of which are connected to the rear metallization with two via rows by means of through-hole plating.

To facilitate the detailed analysis of new SIW components, FHR expanded an existing, internally-developed integral equation method for planar 3D structures. This allows the modeling of SIW components with minimum computational effort and greatly reduced data volumes compared to commercial methods.

An SIW can be modeled using an analytically derived parallel plate medium, in which both metallizations in the simulation

environment are connected by the original via rows so that the discretization effort is reduced on the vias. Additional recesses or slots for antenna or coupling structures can be modeled with low computational effort using magnetic currents. Discretization is carried out with an internally-developed mesh generator which uses standard drawing programs and therefore offers the developer maximum flexibility at a relatively low cost.

Fast preliminary design and detailed characterization

An SIW can also be used to construct efficient leaky-wave antennas with frequency-controlled beam steering, e.g. an endfire antenna with radiation directly from the edge of a PCB. Here, an internally-developed model analysis method paves the way for the fast preliminary design of the antenna. Thanks to the use of highly compact absorbers (vias with ohmic loss) as line terminations, efficiency levels and loss effects can be calculated directly. Matching (and transmission) are determined using new SIW ports with field monitors for the extraction of the port waves. With these functionalities, additional distribution networks, filter and resonator structures, coupler and phase shifters etc. can be characterized, whereby automatic mesh refinement can – if necessary – take place, above all near the vias.

Development of SIW endfire antennas for array applications

The new method was used by the institute to specify the utilization of horn-shaped structures as endfire antennas for

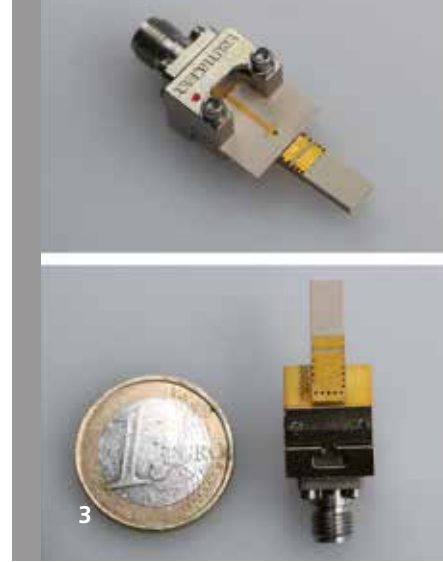
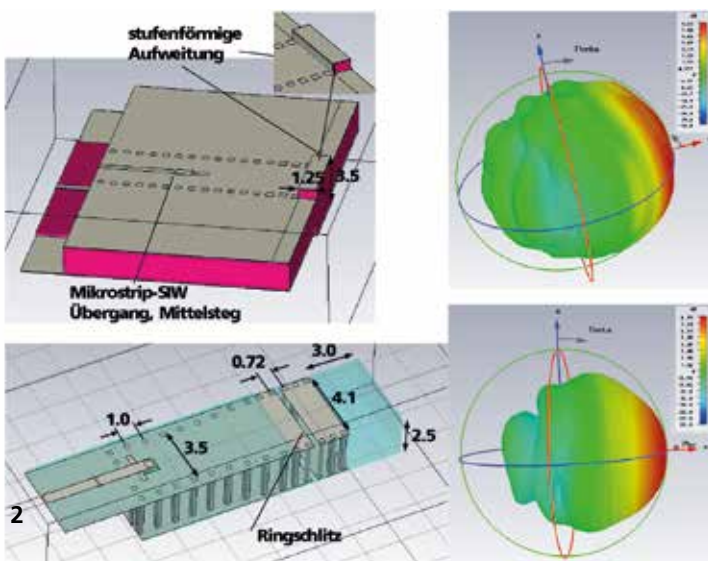

arrays. Here, the element width is not much bigger than half a free space wavelength. With this approach, acceptable radiation behavior can only be achieved through the utilization of a correspondingly thick aperture, which was initially realized with a stepped height expansion at the end of an SIW. This, however, is difficult to fabricate and back radiation is still relatively large (Fig. 2 above). For this reason, an innovative compact structure based on a rectangular-shaped ring slot and a dielectric rod was established. This exhibits a high bandwidth with low back radiation at the same time and is also cheaper to fabricate as height expansion is not required (Fig. 2 below).

This antenna category requires microstrip-SIW transitions where the substrate thickness of the SIW is approximately ten times greater than that of the microstrip line. Such transitions have not been documented to date.

The structure currently favored is based on coupling with a via which is inserted into the SIW from above through an aperture (antipad) at the end of a thin stripline.

In the case of narrowband applications, this via is contacted through up to the back metallization. In the case of broadband transitions, the via only extends into the upper half of the SIW (Fig 1).

An alternative broadband transition based on an SIW line with several center bars, was successfully produced and tested (30-40 GHz) both on its own and together with an antenna element for the Ka-band (Fig. 2 above).

Utilization for narrowband and broadband applications

After further modifications to optimize fabrication, the SIW element with ring slot was used for narrowband applications in the RAWIS (Radar Warning and Information System) project. As only 2 GHz bandwidth was required around 35 GHz, an easy-to-produce microstrip-SIW transition with a through-contacted coupling via was used. Here, the compact size proves to be a great advantage for the densely populated receiving array (Fig. 3).

The antenna element is currently being fabricated with the broadband version of this microstrip-SIW transition for broadband applications e.g. in high resolution airborne SAR systems (Fig. 2 below).

1 Broadband microstrip-SIW transition with via coupling and antipad; below transmission (green) and matching (blue).

2 Broadband-capable SIW antenna elements with their respective radiation characteristics at 35 GHz.

Above: element with several center bars and terminal height expansion. Below: element with ring slot and broadband version of the transition with via and antipad.

3 One of the first very compact SIW elements with ring slot produced for RAWIS.

Dr.-Ing.

Thomas Vaupel

Phone +49 228 9435-225

thomas.vaupel@

fhr.fraunhofer.de

PUBLICATIONS

To ensure that you have an up-to-date overview of our numerous publications in scientific journals and conferences, all of our publications are available with immediate effect on our website.

All publications 2017:

www.fhr.fraunhofer.de/publikationen2017



Publications in scientific journals

www.fhr.fraunhofer.de/publikationen2017-journals



Publications in scientific conferences

www.fhr.fraunhofer.de/publikationen2017-konferenzen



All Fraunhofer publications:

<http://publica.fraunhofer.de>



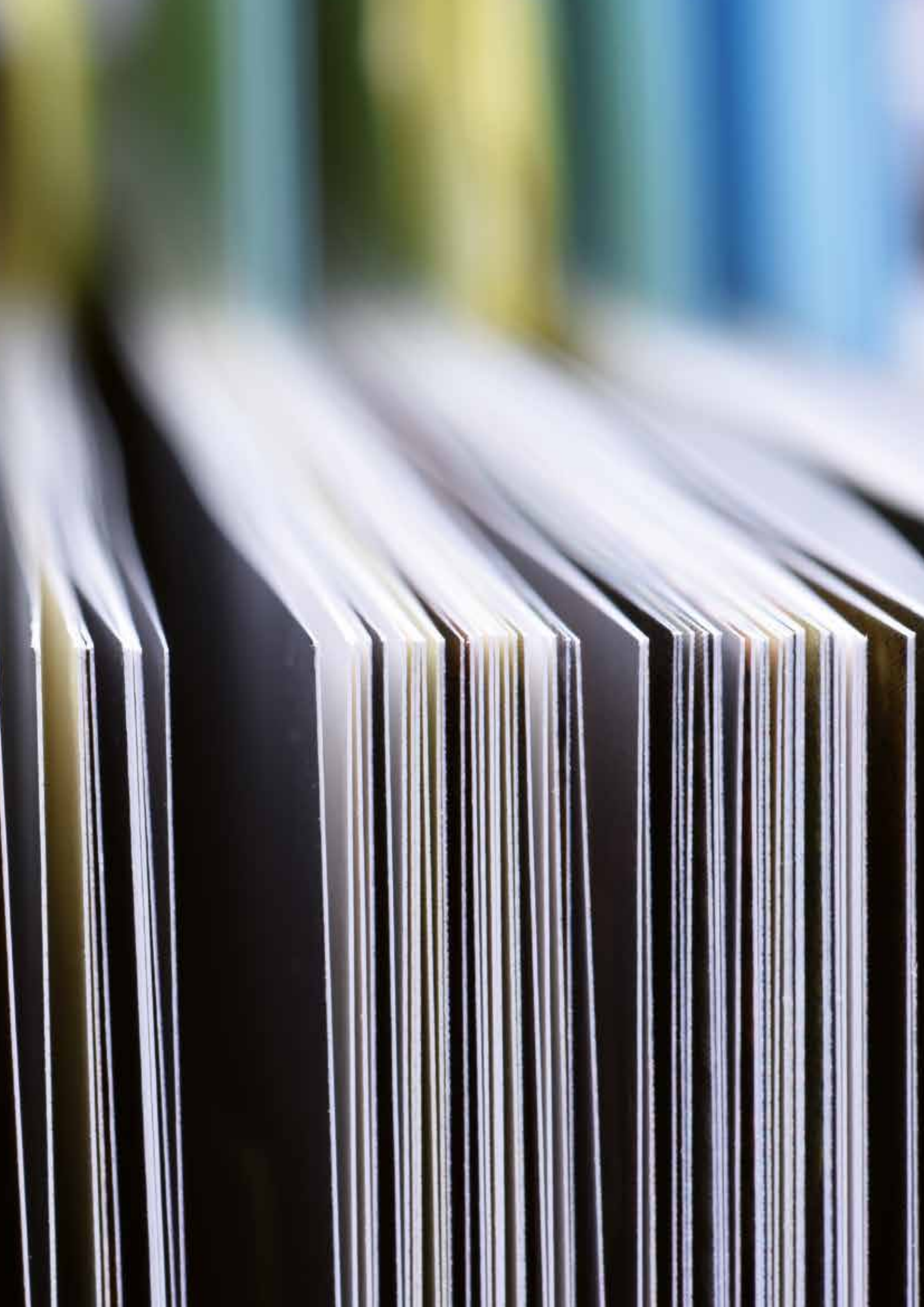

EDUCATION AND TRAINING

Lectures

WS 2016/2017

Bertuch, T.: „Antennen und Wellenausbreitung“, FH Aachen, Aachen, WS 2016/2017

Bongartz, J.: „Signalverarbeitung“, HS-Koblenz, Standort Remagen, WS 2016/2017

Bongartz, J.: „Medizinischer Gerätetechnik“, HS-Koblenz, Standort Remagen, WS 2016/2017

Cerutti-Maori, D.: „Signal Processing for Radar and Imaging Radar“, Vorlesung und Übungen, RWTH Aachen, Aachen, WS 2016/2017

Ender, J.: „Radar – Techniques and Signal Processing I“, Universität Siegen, Siegen, WS 2016/17

Heberling, D.: „Hochfrequenztechnik 1“, RWTH Aachen, Aachen, WS 2016/2017

Heberling, D.: „Moderne Kommunikationstechnik – EMV für Mensch und Gerät“, RWTH Aachen, Aachen, WS 2016/2017

Knott, P.: „Antenna Engineering“, RWTH Aachen, Aachen, WS 2016/2017

Lorenz, F.: „Measuring Techniques“, Hochschule Bonn-Rhein-Sieg, Standort Rheinbach, WS 2016/2017

Pohl, N.: „Integrierte Hochfrequenzschaltungen für die Mess- und Kommunikationstechnik“, Ruhr-Universität Bochum, Bochum, WS 2016/2017

SS 2017

Bongartz, J.: „Funktionsdiagnostik und Monitoring“, HS-Koblenz, Standort Remagen, SS 2017

Bongartz, J.: „Lasermethoden und biomedizinische Optik“, HS-Koblenz, Standort Remagen, SS 2017

Bongartz, J.: „Signalverarbeitung“, HS-Koblenz, Standort Remagen, SS 2017

Caris, M.: „Physikalisches Praktikum“, Hochschule Bonn-Rhein-Sieg, Standort Rheinbach, SS 2017

Bongartz, J.: „Medizinischer Gerätetechnik“, HS-Koblenz, Standort Remagen, WS 2017/2018

Bongartz, J.: „Signalverarbeitung“, HS-Koblenz, Standort Remagen, WS 2017/2018

Caris, M.: „Physikalisches

Praktikum“, Hochschule Bonn-Rhein-Sieg, Standort Rheinbach, WS 2017/2018

Heberling, D.: „Elektromagnetische Felder 2 (IK)“, RWTH Aachen, Aachen, SS 2017

Heberling, D.: „Hochfrequenztechnik 2“, RWTH Aachen, Aachen, SS 2017

Knott, P.: „Radar Systems I“, RWTH Aachen, Aachen, SS 2017

Lorenz, F.: „Risikomanagement in der Supply Chain“, EUFH Köln, Köln, SS 2017

Lorenz, F.: „Physics“, Hochschule Bonn-Rhein-Sieg, Standort Rheinbach, SS 2017

Pohl, N.: „Integrierte Digitalschaltungen“, Ruhr-Universität Bochum, Bochum, SS 2017

WS 2017/2018

Cerutti-Maori, D.: „Signal Processing for Radar and Imaging Radar“, Vorlesung und Übungen, RWTH Aachen, Aachen, WS 2017/2018

Cerutti-Maori, D.: „Radar Systems and Measurements“, Vorlesungsmodul innerhalb der Vorlesung „Raumfahrtrückstände“, TU Braunschweig, Braunschweig, WS 2017/2018

Dankmayer, A.: „Aerospace Remote Sensing“, TU Chemnitz, Chemnitz, WS 2017/18

Ender, J.: „Radar – Techniques and Signal Processing I“, Universität Siegen, Siegen, WS 2017/18

Knott, P.: „Antenna Engineering“, RWTH Aachen, Aachen, WS 2017/2018

Knott, P.: „Radar Systems II“, RWTH Aachen, Aachen, WS 2017/2018

Lorenz, F.: „Measuring Techniques“, Hochschule Bonn-Rhein-Sieg, Standort Rheinbach, WS 2017/2018

Pohl, N.: „Integrierte Hochfrequenzschaltungen für die Mess- und Kommunikationstechnik“, Ruhr-Universität Bochum, Bochum, WS 2017/2018

Pohl, N.: „Elektronik 1: Bauelemente“, Ruhr-Universität Bochum, Bochum, WS 2017/2018

Doctoral dissertations

Brisken, S.: „Motion Estimation and Imaging with Multistatic Inverse Synthetic Aperture Radar“, Naturwissenschaftlich-Technisches Instiut der Uni Siegen, Dr.-Ing.

Dallmann, T.: „Polarimetric Radar Cross-Section Imaging“, Institut für Hochfrequenztechnik der RWTH-Aachen, Dr.-Ing.

Diploma, masters and bachelor theses

Correas Serrano, A.: „Compressed sensing based high-resolution DoA estimation for automotive radar with real measurements“, Technical University of Cartagena, Master of Science

Rodriguez Ferreiro, C.: „Modeling and analysis of micro-doppler signatures for radar target classification“, University of Vigo, Bachelor of Science

Böckler, J.: „Untersuchung dielektrischer Stabantennen zur Anwendung in Bodendurchdringungsradarsystemen“, RWTH Aachen University, Master of Science

Brück, N.: „Verfahren zur Abbildung longitudinal bewegter Objekte für ein MIMO-Radarsystem“, RWTH Aachen, Master of Science

Buckow, S.: „Hochauflösende Umgebungsdarstellung mit schwenkbarem Millimeterwellenradar“, Hochschule Koblenz, Bachelor of Science

Emons, F.: „Entwurf, Optimierung und messtechnische Verifikation eines mehrstufigen gepulsten 300 Watt Verstärkers für Radarapplikationen im S-Band“, Hochschule Bonn-Rhein-Sieg, Master of Engineering

Grenz, O.: „Verlustoptimierung einer breitbandigen, doppelt polarisierten CBSP-Antenne im L-Band mit Betrachtung der Kreuzpolarisationskopplung, Fertigungsaspekten und Phased-Array Tauglichkeit“, Hochschule Bonn-Rhein-Sieg, Master of Engineering

Hansen, S.: „Entwicklung eines Ultra-Breitband FMCW Radar Front-End zur Materialcharakterisierung durch Ellipsometrie im W-Band“, Technische Universität Hamburg, Master of Science

Jukanti, R.: „Development and realisation of a MATLAB radar controller for a coherent MIMO based radar with an integrated digital beamforming processor“, RWTH Aachen, Master of Engineering

Kubach, A.: „Entwurf und Analyse einer mittels 3D-Druckverfahren gefertigten Lüneburg-Linse“, Hochschule Bonn-Rhein-Sieg, Master of Science

Marten, A.: „Movement Trajectory Reconstruction Based on 3D MIMO Radar Data for High Resolution Synthetic Aperture Imaging“, TU Hamburg-Harburg, Master of Science

Müller, P.: „Entwicklung und Implementierung einer CameraLink-Schnittstelle zur Integration eines THz-Sensors in ein inlinefähiges Multi-sensorsystem“, TH Köln, Bachelor of Science

Nair, S.: „Realization of a coherent low noise receiver modul for the integration in an imaging Ka band MIMO radar“, RWTH Aachen, Master of Engineering

Nulwalla, D.: „Untersuchung Integrierbarer Transponder Antennen für ein Maritimes Such und Rettungssystem basierend auf einem harmonischen Radar“, RWTH Aachen University, Master of Science

Öztürk, O.: „Realisierung eine s2-Achsenpositionierers für luftgestützte Radarsysteme unter Verwendung von 3D-Strukturen“, Hochschule Bonn-Rhein-Sieg, Bachelor of Engineering

Rama, J.: „Theoretische Synthese der SAR-Trajektorie eines 3D-Radarscanners im Millimeterwellenbereich“, TU Berlin, Master of Science

Rausch, F.: „Entwicklung, Implementierung und Testen einer modularen Multisensorsuite zur generischen Datenfusion“, Hochschule Koblenz, Master of Science

Schmitz, L.: „Konzeption, Simulation und Design eines gepulsten, zentralen Abwärtsmischmoduls für ein luftgestütztes Ka-Band Radarsystem“, Hochschule Koblenz, Bachelor of Engineering

Schorlemer, J.: „CAD-Entwurf eines abstimmbaren Millimeterwellenoszillators bei einer Mittenfrequenz von 50 GHz in einer modernen SiGe-BiCMOS-Technologie“, Fachhochschule Südwestfalen, Bachelor of Science

Singu, K.: „Investigation of selective microwave heating of lossy dielectric materials with the aid of multiphysics simulations“, Universität Kassel, Master of Science

Vorst, D.: „Schaltungskonzepte zur drahtlosen Energieübertragung“, Hochschule Bonn-Rhein-Sieg, Standort: St. Augustin, Bachelor of Engineering

Weishaupt, F.: „Aufbau und Evaluierung eines MIMO Radarsensornetzwerks sowie signaltheoretische und experimentelle Validierung“, RWTH Aachen, Master of Engineering

Witzler, S.: „Entwurf und Konstruktion des Antennensystems einer MIMO-Radar-Zeile zur hochauflösenden transmittiven Abbildung von Produktionsgütern auf Bandstraßen“, Hochschule Koblenz, Bachelor of Science

Lecturer activities in technical seminars and consulting events

Bertuch T.: „Metamaterialien“, Space InnoSenT Technical Meeting (ITM), Elfershausen, 15.11.2017

Bertuch, T.: „Dispersion Properties of Periodically Loaded Parallel-Plate Waveguides, Analysis and Leaky-Wave Antenna Application“, European School on Antennas (ESoA) Course on Leaky Waves and Periodic Structures for Antenna Applications, 26.-29.4.2017

Caris, M.: „Millimeterwellen und THz-Warnsensorik“, CCG-Seminar SE 3.11, Warnsensorik und Gegenmaßnahmen, 15.11.2017

Cerutti-Maori, D.; Sommer, S.: Workshop „SAR“, 9th International Summer School on Radar/SAR, Remagen, 14-21.7.2017

Cerutti-Maori, D.: „Space surveillance and reconnaissance with radar“, Space situational awareness course, Lehrgang Weltraumlagezentrum, October 2017.

Danklmayer, A.: „Konforme und Strukturintegrierte Antennen“, Vortrag im Rahmen des Laufbahnausbildungslehrgangs für den höheren technischen Dienst in der Fachrichtung Informationstechnik und Elektronik am Bildungszentrum der Bundeswehr in Mannheim, 12.6.2017

Danklmayer, A.: „Radarstreuung und Wellenausbreitung“ plus Tutorial, CCG Seminar SE 2.01, Grundlagen der Radartechnik, 17.5.2017

Danklmayer, A.: „Workshop on Polarimetric SAR“, International Summerschool on Radar/SAR, 19.-20. 07.2017

Ender, J.: „Cognitive Radar and CS with Radar“, 9th International Summer School on Radar/SAR, Remagen, 14.-21.7.2017

Heberling, D.: „Antennas and Hardware Aspects“, 9th International Summer School on Radar/SAR, Remagen, 14.-21.7.2017

Klare, J.; Biallawons, O.; Cerutti-Maori, D.: „MIMO Radar for UAV Detection“, Workshop SF-02 on Radar Based Detection of Drones, European Microwave Week (EuWM) 2017, 8.-13.10.2017

Kuschel, H.: „Passive Radar History and Fundamentals“, und „Passive Radar Applications“, NATO SET 243 Lecture Series on Passive Radar Technology, 6.9.- 10.11.2017, USA , IT, PL

Matthes, D.; Worms, J.: „Überblick Fraunhofer FHR und Abteilung PSR“, „Radar-EloKa 'Heute und in Zukunft'“, „Radar ECM/ ECCM – Allgemeine Aspekte“, „Radar ECM – Stör- und Täuschverfahren gegen moderne Radarsysteme“, „Radar-EloKa Tutorial“, für Zentrum Luftoperationen Bw, 25.09.2017

Schumacher, R.: „Nichtkooperative Ziel-Identifizierung und ATR“, „Passives Radar“, und „Meterwellenradar zur Detektion RCS-reduzierter

Ziel“, CCG-Seminar SE 2.14, Radar-, VIS- und IR-Signaturen, Technik und Anwendungen, 30.11.2017

Turso, S.: Workshop „Radar system design including antenna front-end aspects“, 9th International Summer School on Radar/SAR, Remagen, 14-21.07.2017

Weiß, M.: „Radar Fundamentals“, 9th International Summer School on Radar/SAR, Remagen, 14.-21.7.2017

Wojaczek, P.; Kuschel, H.: Workshop „Bistatic Radar – A work in progress“, 9th International Summer School on Radar/SAR, Remagen, 14.-21.7.2017



COMMITTEE WORK

Brüggenwirth, S.:

- International Radar Symposium (IRS) 2017, Prag: Chairman und Reviewer
- IEEE Aerospace and Electronic Systems Society, Germany Chapter: Secretary
- RADAR-CapTech, European Defence Agency: German Government Expert

Cerutti-Maori, D.:

- International Conference on Radar Systems 2017, Belfast: Technical Programme Committee Mitglied
- International-Agency Space Debris Coordination Committee: Nationale Vertreterin in der Working Group 1 (Measurements)
- International Geoscience and Remote Sensing Symposium (IGARSS) 2017: Technical Review Committee

Cristallini, D.:

- NATO-Set 242 PCL on Mobile Platforms: Co-Chair
- IET International Conference on Radar Systems 2017, Belfast: Technical Programme Committee
- European Radar Conference (EuRAD) 2017: Technical Programme Committee
- IEEE International Conference on Aerospace Electronics and Remote Sensing Technology (ICARES) 2017: Technical Programme Committee

Danklmayer, A.:

- International Union of Radio Science Wave Propagation and Remote Sensing: Mitglied der Kommission
- European Conference on Antennas and Propagation (EuCAP) 2017: Technical Review Committee

- German Microwave Conference (GeMiC) 2017: Technical Review Committee
- International Radar Symposium 2017: Technical Program Committee
- International Geoscience and Remote Sensing Symposium (IGARSS) 2017: Technical Review Committee
- VDE-ITG – Fachausschuss 7.5 Wellenausbreitung: Mitglied
- Deutsche Gesellschaft für Ortung und Navigation e.V.: Mitglied im Fachausschuss für Radartechnik

Ender, J.:

- International Radar Symposium 2017: Technical Program Committee
- European Conference on Synthetic Aperture Radar (EUSAR) 2018: Technical Program Board
- Mitglied im Rat der DGON (Deutsche Gesellschaft für Ortung und Navigation)
- Fellow des IEEE (Institute of Electrical Electronics Engineers)
- VDI-ITG Fachbereich 7: Fachbereichsleiter HF-technik

Heberling, D.:

- ITG-Fachausschuss 7.1 „Antennen“: Vorsitzender
- European Conference on Antennas and Propagation (EuCAP) 2017, Paris: Mitorganisator, Mitglied des Steering Committees
- Zentrum für Sensordysteme (ZESS) 2017, Siegen: Wissenschaftlicher Beirat
- Antenna Measurement Technique Association (AMTA) 2017, Atlanta: President
- Deutsche Forschungsgemeinschaft (DFG) : Fachkollegiat

Klare, J.:

- International Radar Symposium (IRS) 2017: Mitglied des Technical Program Committee
- IEEE International Conference on Aerospace Electronics and Remote Sensing Technology(ICARES): Mitglied des Technical Program Committee
- International Conference on Electrical Engineering, Computer Science and Informatics (EECSI), Yogyakarta, Indonesia, 2017: Mitglied des Technical Program Committee

Knott, P.:

- Informationstechnische Gesellschaft (ITG), Fachgruppe 7.1 Antennen: Stellvertretender Vorsitzender
- IEEE Microwave Theory and Techniques (MTT) / Antennas and Propagation (AP) Joint Chapter, Executive Committee: Chair
- Deutsche Gesellschaft für Ortung und Navigation (DGON) e.V.: Mitglied im Wissenschaftlichen Beirat, Vorsitzender Fachausschuss Radartechnik
- European Radar Conference (EuRAD) im Rahmen der European Microwave Week (EuMW) 2017, Nürnberg: Secretary

Kuschel, H.:

- NATO-Set 195 DMPAR verification of short term solution: Chairman
- NATO-Set 242 PCI on mobile platform : Chairman

Leushacke, L.:

- Inter-Agency Space Debris Coordination Committee: Nationaler Vertreter in der Working Group 1 (Measurements)

Matthes, D.:

- NATO-SCI 281 Solutions Advancing next Generation Radar Electronic Attack: Chairman

Nüßler, D.:

- Optical Characterization of Materials (OCM) 2017: Program-Committee

Nuncio Quiroz, E.A.:

- International Conference on Telecommunications and Remote Sensing (ICTRS) 2017, Delft: Program Committee

Pohl, N.:

- European Radar Conference (EuRAD) 2017: Technical Program Committee Chair
- VDI Fachkonferenz "Sensoren für mobile Maschinen": Konferenzleitung

Uschkerat, U.:

- DEA 1670 Counter Mine: Projektmitglied
- EDA-RFST: National Expert
- NATO-SET 208 Signal Processing for Implementation in Hand-Held Multi-Sensor Ground Penetrating System 2017: Co-Chair

Vaupel, T.:

- International Conference on Broadband Communication (BCWSP), Wireless Sensors and Powering 2017, Jakarta: Mitglied Technical Program Committee

Weinmann, F.:

- European Conference on Antennas and Propagation (EuCAP) 2017, Paris: Technical Review Committee

Weiß, M.:

- European Conference on Synthetic Aperture Radar (EUSAR) 2018: Executive Board-Mitglied, Technical Chair
- 6th PCL Focus Days 2017, Wachtberg: Technical Chair
- NATO-SET 235 Radar and SAR Systems for Airborne and Space-based Surveillance and Reconnaissance: Lecture Series Director and Lecturer
- IET Signal Processing Magazine: Editorial Mitglied
- IEEE Geoscience and Remote Sensing Society (GRSS): Program Committee Member
- IRS 2017, Prag: Program Committee Member
- Radar Conference (RadarConf17) 2017, Westin Seattle: Committee Member
- European Microwave Week (EuMW) 2017, Nürnberg: Program Committee Member
- NATO-Set 236 Design and Analysis of Compressive Sensing Techniques for Radar and ESM Applications: Compressive Sensing Experte

Worms, J.:

- IET International Conference on Radar Systems 2017, Belfast: Technical Program Committee



AWARDS

Gracheva, V.: Dissertationspreis 2017 der ITG für ihre Dissertation „Multichannel Analysis of Medium Grazing Angle Sea Clutter for Airborne Microwave Radar Systems“

Lambert, O.: AFCEA Studienpreis 2017, zweiter Platz für seine Masterarbeit „Adaption und Implementierung von systeminhärenten HF-Charakterisierungsmethoden für ein nach dem SDR-Prinzip arbeitendes Empfangsmodul für ein Phased-Array-Radar“

Pohl, N.: International IHP „Wolfgang Mehr“ Fellowship Award 2017

Rahlf, B.: Jahrgangsbester Feinwerkmechaniker-Azubi in der Innung Bonn-Rhein-Sieg

Vaupel, T.: Best Paper Award für „Application of a TSMFM Planar-3D Fast Integral Equation Solver for Surface Wave Characterization of Antenna Arrays“ auf der BCWSP 2017 Conference in Jakarta, Indonesien

EVENTS

Conference Organisation

Workshop „Radartechnologie zur UAV-Detektion“, 14.03.2017, Wachtberg

„PCL-Focus Days“, 21.-23.5.2017, Wachtberg

„Wachtberg-Forum“, 22.6.2017, Wachtberg

„Kuratoriumssitzung“, 23.6.2017, Wachtberg

„Tag der offenen Tür 2017“, 25.6.2017, Wachtberg

„International Summer School on Radar/SAR“, 14.-21.07.2017, Remagen

„EDA-Workshop on Radar Signatures and EM Benchmarks“, 7.11.2017, Brüssel

Participation in fairs and Exhibitions

Fraunhofer FHR-Stand bei der 7th „European Conference on Space Debris“, 18.-21.4.2017, Darmstadt

Beteiligung am Gemeinschaftsstand der Fraunhofer-Allianz Vision bei der „Control“, 9.5.-12.5.2017, Stuttgart

Pressekonferenz mit Ausstellung zum Förderprogramm „Forschung für die zivile Sicherheit“ vor Vertretern des BMBF und BMI mit den Konsortialpartnern: Vorstellung des Projektes: „Radar-Warn- und Informationssystem für Anwendungen im Katastrophenschutz, (RAWIS)“, 5.7.2017, Berlin

Beteiligung am Fraunhofer-TNO Gemeinschaftsstand bei der „European Microwave Week (EUMW)“ 2017, 08.-13.10.2017, Nürnberg

Beteiligung am Gemeinschaftsstand der Fraunhofer-Allianz Space bei der „Space Tech Expo Europe“, 24.-26.10.2017, Bremen

Beteiligung am Gemeinschaftsstand der Fraunhofer-Allianz Verkehr bei der „Hypermotion“, 22.11.2017, Frankfurt

Beteiligung am Gemeinschaftsstand des Fraunhofer-Verbunds Mikroelektronik im Rahmen der Forschungsfabrik Mikroelektronik Deutschland (FMD) auf der „Productronica“, 14.-17.11.2017, München

Beteiligung am Gemeinschaftsstand der Fraunhofer-Gesellschaft beim „Absolventenkongress“, 23.-24.11.2017, Köln

Fraunhofer FHR-Stand bei der „Bonding“, 6.12.2017, Aachen

PRESS REVIEWS

Day	Title	Medium
19.01.17	Mobil Gefahrenbereiche erkennen	Rheinische Post
04.03.17	Die unendlichen Weiten der Mathematik	Blick Aktuell
07.03.17	Namen und Notizen	General-Anzeiger
22.03.17	Radarforscher wollen expandieren	General-Anzeiger
29.03.17	Technologische Souveränität schaffen und ausbauen	Behörden Spiegel
04.04.17	Streubomben- international geächtet, in Syrien im Einsatz	Sueddeutsche.de
04.04.17	Besichtigung des Radoms zu gewinnen	Kölnische Rundschau
05.04.17	Einzigartige Führung durch die Labore und die Kugel zu gewinnen	Blick Aktuell
08.04.17	Einblick in die weiße Kugel	General-Anzeiger
21.04.17	Im All wirds eng	General-Anzeiger
22.04.17	Im All wirds eng	Kölnische Rundschau
24.04.17	Bildverarbeitung für das Produktionsmonitoring	Control express
27.04.17	Eingehüllt in eine Schrottwolke	Berliner Zeitung
28.04.17	Wissenschaft und Forschung zum Anfassen	General-Anzeiger
02.05.17	At London SSA conference calls for paradigm in shift in space situational awareness	Space News
09.05.17	Radar-Chip überprüft Produktionsprozesse	pro-physik
11.05.17	Fakten und Sehenswürdigkeiten	General-Anzeiger
12.05.17	Einzigartige Führung durch die Kugel	Kölnische Rundschau
13.05.17	So lassen Sie "Kugeln" schweben	Hanser-Konstruktion
22.05.17	Wachtbergforum	BehördenSpiegel
26.05.17	Die Radaranlage feiert in diesem Jahr ihren 60 Geburtstag	KE-Next.de
02.06.17	Sicherheitsmaßnahmen beim Gipfel	Galileo
03.06.17	Greifer und Laser	Süddeutsche Zeitung
04.06.17	Weltraumschrott - Kehraus im Weltraum	Süddeutsche.de
06.06.17	Fraunhofer-Institut: Bund fördert Mikroelektronik	General-Anzeiger
06.06.17	Wo Zukunft entsteht	General-Anzeiger
07.06.17	Fraunhofer-Institut Wachtberg: Bund fördert Sicherheitsforschung mit 9,3 Millionen Euro	Bonner Rundschau
07.06.17	Startschuss für Forschungsfabrik Mikroelektronik Deutschland	Blick Aktuell

Day	Title	Medium
08.06.17	Geldsegen für Blick in die Zukunft	Kölnische Rundschau
26.06.17	Weltraumforscher erlauben Blick ins Radom	General Anzeiger
10.07.17	Massive Ausschreitungen in Hamburg	Behörden Spiegel
12.07.17	Projekt Rawis vorgestellt	Blick Aktuell
19.07.17	Forschungsfabrik Mikroelektronik nimmt Gestalt an	Elektroniknet
21.07.17	Terror-Gefahr durch Drohnen	Swr2
15.10.17	Gestra soll Unfälle im Weltraum verhindern	n-tv
16.10.17	Schmidtenhöhe bekommt Weltraumradar: In Koblenz wird bald Weltraumschrott geortet	SWR Aktuell
16.10.17	Unfallschutz im Weltall	Trierischer Volksfreund
16.10.17	Unfallfrei durch den Weltraum	Märkische Allgemeine
16.10.17	Radar warnt vor Müll	Ruhr Nachrichten
16.10.17	Radar warnt vor Müll	Münstersche Zeitung
16.10.17	Radar warnt vor dem Müll	Recklinghäuser Zeitung
16.10.17	Radar für unfallfreien Weltraum	Kölner Stadt-Anzeiger
16.10.17	Neues Radar soll für einen unfallfreien Weltraum sorgen	Saarbrücker Zeitung
16.10.17	Müll schneller als eine Gewehrkegel	Siegener Zeitung
16.10.17	In Koblenz wird bald Weltraumschrott geortet	Swr
16.10.17	Schrott soll Satelliten nicht schrotten	Elektroniknet
17.10.17	Koblenzer Radar spürt Schrott im Weltall auf	Rheinzeitung
24.11.17	Wie Forscher das Weltall überwachen	Rhein Zeitung
01.12.17	Historisches trifft Modernes vor Bonner Panorama	Rhein Zeitung



LOCATIONS

The Fraunhofer Institute for High Frequency Physics and Radar Techniques FHR has five locations in North-Rhine Westphalia.

Head office and postal address

Fraunhofer FHR
Fraunhoferstr. 20
53343 Wachtberg
Germany

Phone +49 228 9435-227
Fax: +49 228 9435-627

info@fhr.fraunhofer.de
www.fhr.fraunhofer.de/en

Institute branch Wachtberg-Villip

Siebengebirgsblick 22
53343 Wachtberg-Villip
Germany

Phone: +49 228 9435-159
Fax: +49 228 9435-192

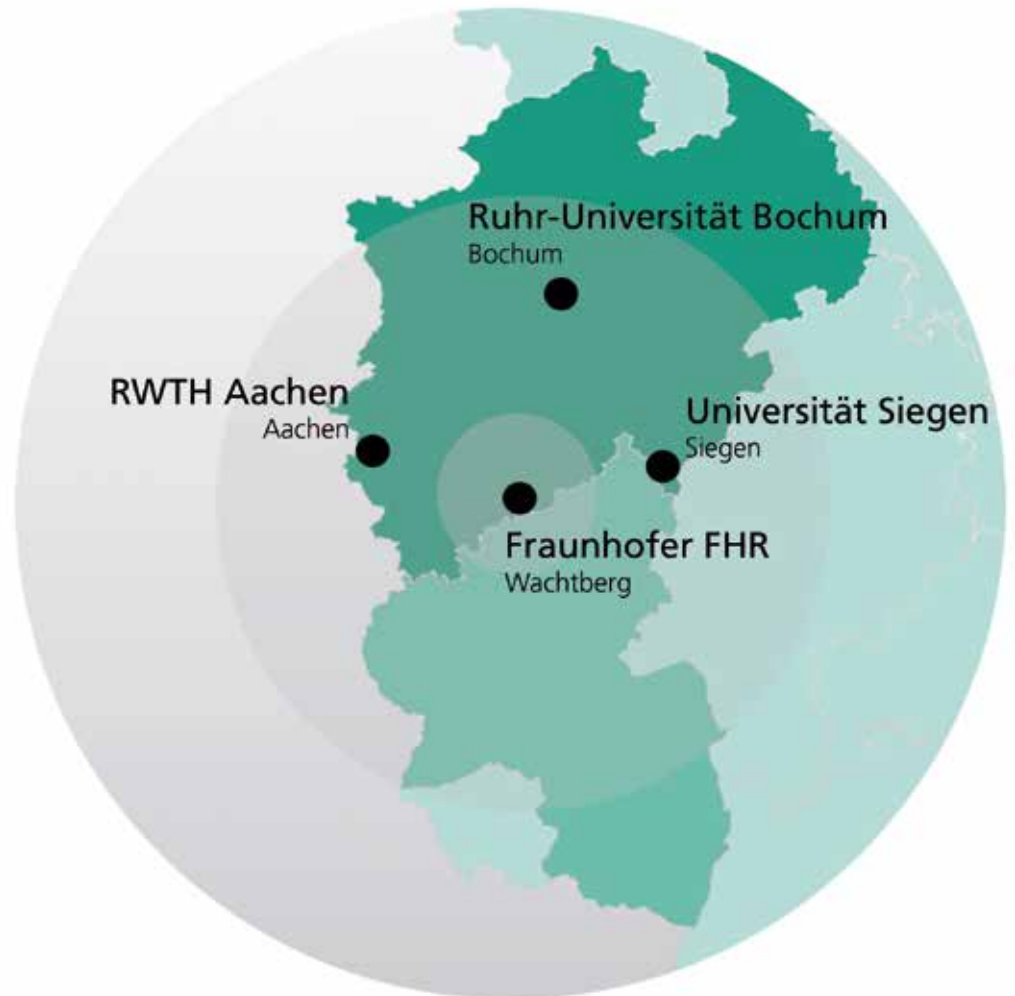

Research groups at universities

Research group Aachen

Melatener Str. 25
52074 Aachen
Germany

Phone +49 241 80-27932
Fax: +49 241 80-22641

Research group Bochum

Universitätsstraße 150
44801 Bochum
Germany

Phone +49 234 32-26495
Fax: +49 234 32-06495

Research group Siegen

Paul-Bonatz-Str. 9-11
57076 Siegen
Germany

Phone +49 271 740-3400
Fax: +49 271 740-4018

IMPRINT

Publisher

Fraunhofer Institute for High Frequency Physics
and Radar Techniques FHR
Fraunhoferstr. 20
53343 Wachtberg
Germany

Phone: +49 228 9435-227
Fax: +49 228 9435-627
info@fhr.fraunhofer.de
www.fhr.fraunhofer.de/en

Bilder

© Fraunhofer FHR, except:
P. 6: R WTH Aachen
P. 9, Fig. 2: © Leibniz-Institut für innovative Mikroelektronik
P. 10, Fig. 3, Fig. 5, Fig. 6, P. 12: © Hans-Jürgen Vollrath
P. 24, Fig. 1: © IHF
P. 25, Fig. 2: © Ruhr-Universität Bochum
P. 25, Fig. 3: © ZESS
P. 28, Fig. 3: © Shutterstock
P. 32/33, text und figures: © Institution of Engineering &
Technology (IET) / Fraunhofer FHR (Reproduced by permission
of the Institution of Engineering & Technology)
P. 35, Fig. 1, Fig. 2: © armasuisse / Fraunhofer FHR
P. 64, Fig. 1: Fotolia

Editor

Dipl.-Volksw. Jens Fiege
M. Sc. Hanne Bendel
Dipl.-Biol. Christiane Weber

Layout and typesetting

B. A. Jacqueline Reinders

Social Media



Twitter
http://www.twitter.com/Fraunhofer_FHRe



Facebook
<http://www.facebook.com/Fraunhofer.FHR>



Youtube
<https://www.youtube.com/channel/UC0dHBWZqhYaqBE7R37rDnrA>

All rights reserved.
Reproduction and dissemination only with the prior consent of
the editor.

Wachtberg, July 2018

